



2015 ACCESSORIES

V7 II

STONE



MOTO GUZZI®





**PARABREZZA  
WINDSHIELD**

.....  
COD. 8877724

Studiato appositamente per offrire la massima protezione aerodinamica senza tralasciare l'attenzione al design. Omologato secondo i più severi standards DOT e TUV e testato in ogni condizione.

*Designed specifically to offer the maximum aerodynamic protection without neglecting the attention for the design. Approved according the most severe DOT and TUV standards and tested in all conditions.*



**GUZZI MULTIMEDIA PLATFORM  
GUZZI MULTIMEDIA PLATFORM**

.....  
COD. 2S000157

GMP è il nuovo dispositivo che consente di collegare il proprio Smartphone alla moto, trasformandola in una vera e propria piattaforma multimediale. Per l'installazione utilizzare il supporto dedicato 2S000170.

*GMP is the new device that allows you to connect your smartphone to the motorcycle, turning it to a real multimedia platform. To mount it, use the dedicated bracket 2S000170.*



**COVER STRUMENTI  
IN ALLUMINIO SATINATO  
SATIN-FINISHED ALUMINIUM  
TOOLS COVER**

.....  
COD. 606181M

Mostrina in alluminio satinato a mano, sostituisce la parte di produzione verniciata nera. Solo per V7 II.

*Hand satin-finished aluminium panel, replacing the black painted production part. Only for V7 II.*



**MANUBRIO CROMATO  
CHROMED HANDLEBAR**

.....  
COD. 2S000174

Manubrio cromato, per una personalizzazione esclusiva della propria V7.

*Chromed handlebar for a an exclusive V7 customising.*



**CUPOLINO  
TOP FAIRING**

.....  
COD. 886995

Il kit comprende il cupolino in materiale plastico stampato (al grezzo) e i supporti in alluminio con relativa viteria.

*The kit includes a plastic moulded top fairing (unfinished) and the aluminium brackets with relative nuts and bolts.*



**KIT SUPPORTO CENTRALINA GMP  
GMP INSTALLATION KIT**

.....  
COD. 2S000170

Kit supporto dedicato al fissaggio del GMP, non necessita di cablaggi in quanto già predisposti nella moto.

*Dedicated bracket kit for fastening the GMP, does not require wiring harness since it is already provided on the motorcycle.*



**SEMIMANUBRI CROMATI  
CHROMED SEMI-HANDLEBAR**

.....  
COD. 2S000176

Kit di semimanubri cromati, completo di cavi e tubi per versione ABS, per cambiare l'impostazione della tua V7 in qualcosa di ancora più sportivo

*Kit of chromed semi-handlebars, complete with cables and tubes for ABS version, to change the setting of your V7 into something even more sporty.*



**KIT COPERCHIO INIETTORI  
INJECTOR COVERS KIT**

.....  
COD. 886996

La coppia di coperchi iniettori permette di proteggere questi ultimi dal contatto accidentale con le ginocchia del guidatore.

*The injector covers protects them against accidental contact with the driver's knees.*



**FIANCATINE IN ALLUMINIO  
ALUMINIUM SIDE FAIRINGS**

.....  
COD. 886994

Le fiancattine in alluminio spazzolato e anodizzato rendono V7 ancora più bella: ne snelliscono i fianchi e richiamano le creazioni artigianali tipiche delle gare per derivate di serie degli anni 70.

*The brushed and anodized aluminium fairings make your V7 even more attractive: they slim down the sides and are reminiscent of the hand crafted creations which were typical of factory derivative series in the 70's.*

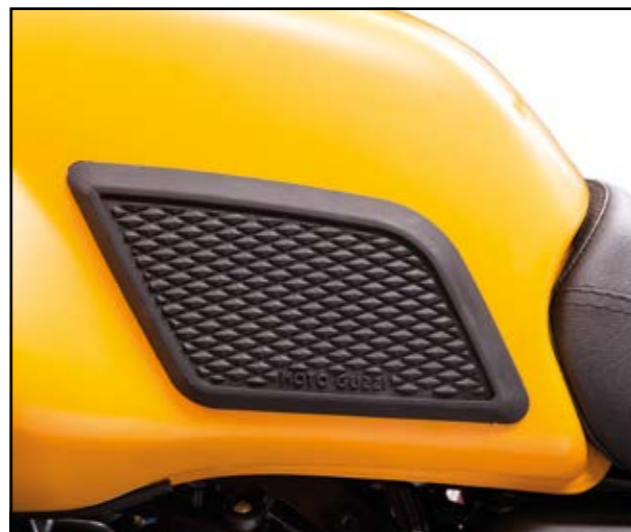

**PROTEZIONI SERBATOIO  
TANK PROTECTION**

.....  
COD. 897021

Coppia di paraginocchia adesivi in morbida gomma da applicare ai lati del serbatoio, caratterizzati da un disegno a rombi e impreziositi dal logo Moto Guzzi.

*Adhesive soft rubber knee pads to be applied on the tank sides, with rhombus design and enriched with the Moto Guzzi logo.*



**SELLA COMFORT GEL  
COMFORT GEL SADDLE**

.....  
COD. B063597

Sella biposto con inserti in gel nelle zone pilota e passeggero. Oltre al comfort, offre un maggior appoggio a terra grazie al diverso disegno dello schiumato. Logo "Comfort Gel" punzonato.

*Two seat saddle with gel inserts in the driver and passenger area. Besides comfort, it offers better contact with ground due to the different design of the foamed structure. Punched "Comfort Gel" logo.*



**SELLA RIBASSATA COMFORT GEL  
LOWER COMFORT GEL SADDLE**

.....  
COD. B063598

Biposto, unisce il comfort del gel alla comodità del profilo rivisto e ribassato, per consentire al pilota un migliore e più sicuro appoggio a terra. Logo "Comfort Gel" punzonato.

*Two-seated, combines the comfort given by the gel with the revised and lowered profile, to allow the driver to have a better and safer contact with the ground. Punched "Comfort Gel" logo.*



**COPRISERBATOIO CON BORSELLO  
TANK COVER WITH POCKET**

.....  
COD. B063837

Realizzato in pelle con trattamento antiacqua, offre una comoda tasca portaoggetti e portadocumenti poco ingombrante.

*Made of leather with waterproof treatment, it offers a convenient object holder pocket and small document carrier.*



**BORSA CON COPRISERBATOIO  
TANKBAG WITH TANK COVER**

.....  
COD. B063838

Borsa serbatoio in nylon e vera pelle idrorepellente, dotata di 2 tasche laterali e una superiore portacartina. Si fissa tramite agganci rapidi al copriserbatoio, che può restare montato sul serbatoio grazie al foro per il rifornimento ed è facilmente sganciabile e trasportabile grazie alla pratica maniglia.

*Waterproof tank bag in nylon and leather, equipped with 2 side pockets and a top map holder. The bag connects through fast clips to the tank cover that can stay mounted on the tank thanks to the refuelling hole, being easily detachable and carried using the practical handle.*



**PEDANE PILOTA IN ALLUMINIO  
PILOT ALUMINIUM FOOTPEGS**

.....  
COD. 2S000168

Pedane anteriori in alluminio, alleggerite e dalla linea sportiva, accentuano lo spirito racing della V7.

*Front aluminium footpegs, add lightness and sportive line, they highlight the racing spirit of the V7.*



**PEDANE PASSEGGERO IN ALLUMINIO  
PASSENGER ALUMINIUM FOOTPEGS**

.....  
COD. 2S000169

Pedane posteriori in alluminio, alleggerite e dalla linea sportiva, accentuano lo spirito racing della V7.

*Rear aluminium footpegs, add lightness and sportive line, they highlight the racing spirit of the V7.*





**PEDANE ARRETRATE  
RACING FOOTRESTS**

.....  
COD. 886954

Le pedane arretrate garantiscono una posizione di guida più sportiva e sono l'ideale complemento dei semimanubri che equipaggiano le café racers.  
*The swept back pedals guarantee a more sportive driving position, being the ideal complement of the semi-handlebars provided on the café racers.*



**KIT SUPPORTO USB  
USB SOCKET KIT**

.....  
COD. 2S000166

Presse USB fornita di supporto dedicato per installazione nel sottosella, per la ricarica dei supporti elettronici, non consente il dialogo con gli apparati elettronici del mezzo.  
*USB socket with bracket for installation under the saddle, to recharge the electronic media, does not allow dialogue with the electronic devices of the vehicle.*



**MOLLE AMMORTIZZATORI ROSSE  
RED SHOCK ABSORBER SPRINGS**

.....  
COD. 2S000175

Molle di colore rosso da sostituire a quelle nere negli ammortizzatori di serie della V7 II.  
*Red springs to replace the black ones in the V7 II series shock absorbers.*



**MANIGLIE PASSEGGERO  
PASSENGER HANDGRIPS**

.....  
COD. 2S000206

Supporto aggiuntivo per consentire un migliore comfort del passeggero.  
*Additional bracket to offer a better comfort to the passenger.*



**KIT BUSSOLE FORATE  
DRILLED BUSHING KIT**

.....  
COD. 2S000172

Tre bussole forate, per migliorare l'estetica della V7, si applicano in corrispondenza degli attacchi degli ammortizzatori.  
*Three drilled bushings to improve the look of the V7, applied in correspondence with the shock absorber fittings.*



**AMMORTIZZATORI PERFORMANCE  
PERFORMANCE SHOCK ABSORBER**

.....  
COD. 897773 NERO/BLACK  
COD. 606091M ROSSO/RED

Con serbatoio gas separato, regolabili in estensione, compressione e precarico, migliorano comfort e guidabilità grazie alle eccezionali caratteristiche tecniche che li contraddistinguono.  
*With Piggy Back chamber, adjustable in extension, compression and preload, improved comfort and handling thanks to exceptional technical features that distinguish them.*



**PORTAPACCHI  
REAR RACK**

.....  
COD. 983163

Realizzato in acciaio cromato, si fissa al posto delle maniglie passeggero, che sostituisce grazie all'ampio maniglione integrato.  
*Made of chromed steel, it is mounted in place of the passenger handle that it replaces thanks to the large integrated handle.*



**BORSE LATERALI  
SIDE BAGS**

.....  
COD. 983162

Kit composto dalla coppia di valigie rigide in nylon, del volume di circa 20 litri, rivestite in vera pelle idrorepellente e dotate di chiusura con fibbia in acciaio cromato, telaio di fissaggio in acciaio ad alta resistenza e coppia di borse interne asportabili in nylon. NB: solo per versione Classic.  
*Kit composed by a pair of Nylon rigid cases, around 20 litres capacity, covered by water-repellent coated leather, with chromed steel buckle closing system, high-resistance steel clamping frame and internal detachable nylon bags. NOTE: Only for Classic version.*



**VALIGIE SEMIRIGIDE  
COMPLETE DI SUPPORTI  
SEMI-RIGID PANNIERS KIT  
WITH BRACKETS**

.....  
COD. B063096

Valigie semirigide in poliestere complete di cuffie anti-pioggia termosaldate, dotate di sistema di aggancio/sgancio rapido Fast Click. Necessitano di portapacchi.

*Polyester semi-rigid bags with thermoformed rain covers, equipped with hook/quick release system Fast Click. Require luggage carriers.*



**BORSA BAULETTO  
REAR TOPBAG**

.....  
COD. 983308

Borsa bauletto in vera pelle idrorepellente, si fissa al portapacchi dedicato tramite comode cinghie e può essere facilmente asportata grazie alla maniglia posteriore.

*Water repellent top box bag made of true leather, mounted to the dedicated luggage carrier with practical straps, can be easily detached thanks to its rear handle.*



**TELO COPRIMOTO V7  
V7 BIKE COVER**

.....  
COD. 895729

Telo su misura da interno per la protezione dalla polvere da utilizzare durante le soste in garage della moto.

È realizzato in un tessuto elasticizzato con grafica speciale.

*Tailor-made motorcycle cover for inside use to protect against dust, intended for use during long periods of storing the bike in a garage. It is made of stretch fabric with special graphics.*



**KIT RECORD  
RECORD KIT**

.....  
COD. 606179M

**CUPOLINO ANTERIORE/FRONT FAIRING  
COD. 606180M CODONE SELLA/TAIL SEAT**

Disegnato dal centro Stile Moto Guzzi, richiama le forme aerodinamiche delle racer anni '70 ed è realizzata in vetroresina. Il kit si compone di un cupolino anteriore tondeggiante (cod. 606179M) che incorpora il faro singolo centrale della V7, completato da due profili laterali che raccordano la carenatura alla zona serbatoio. La sella viene invece sostituita da un unico elemento (cod. 606180M) che incorpora anche il codone, sagomato a formare uno spoiler nella sua parte terminale. La seduta sportiva è realizzata in uno speciale materiale schiumato bicomponente, ignifugo ed idrorepellente con memoria di forma, il massimo della tecnologia di diretta derivazione agonistica. Il kit è comprensivo dello staffaggio anteriore in acciaio tagliato al laser e sabbiato e rispetta i criteri omologativi vigenti. È necessario montare i semimanubri.

*Designed by the Moto Guzzi Style Centre, it echoes the aerodynamic shapes of the '70s racer vehicles and it is made of fibreglass. The kit consists of a roundish front top fairing (cod. 606179M) that incorporates the single central headlamp of V7, completed by two side profiles which connect the fairing to the tank area. The saddle is replaced by a single element (cod. 606180M) which also includes the tail, shaped to form a spoiler in the tail. The sport saddle is made in a special two-component, fire and waterproof memory foam material, the best technology directly from the sport world. The kit includes the front clamping made in laser-cut sanded steel, and meets the approval requirements. Mounting requires Semi-handlebars.*



**TELO COPRIMOTO "EAGLE"  
"EAGLE" BIKE COVER**

.....  
COD. 606028M0001

Telo su misura da interno per la protezione dalla polvere da utilizzare durante le soste in garage della moto.

È realizzato in un tessuto elasticizzato con grafica speciale.

*Tailor-made motorcycle cover for inside use to protect against dust, intended for use during long periods of storing the bike in a garage. It is made of stretch fabric with special graphics.*



**TELO COPRIMOTO "SHAPE"  
"SHAPE" BIKE COVER**

.....  
COD. 606028M0002

Telo su misura da interno per la protezione dalla polvere da utilizzare durante le soste in garage della moto.

È realizzato in un tessuto elasticizzato con grafica speciale.

*Tailor-made motorcycle cover for inside use to protect against dust, intended for use during long periods of storing the bike in a garage. It is made of stretch fabric with special graphics.*





**V7 II**

**SPECIAL**

  
**MOTO GUZZI®**





**PARABREZZA  
WINDSHIELD**

.....  
COD. 8877724

Studiato appositamente per offrire la massima protezione aerodinamica senza tralasciare l'attenzione al design. Omologato secondo i più severi standards DOT e TUV e testato in ogni condizione.

*Designed specifically to offer the maximum aerodynamic protection without neglecting the attention for the design. Approved according the most severe DOT and TUV standards and tested in all conditions.*



**GUZZI MULTIMEDIA PLATFORM  
GUZZI MULTIMEDIA PLATFORM**

.....  
COD. 2S000157

GMP è il nuovo dispositivo che consente di collegare il proprio Smartphone alla moto, trasformandola in una vera e propria piattaforma multimediale. Per l'installazione utilizzare il supporto dedicato 2S000170.

*GMP is the new device that allows you to connect your smartphone to the motorcycle, turning it to a real multimedia platform. To mount it, use the dedicated bracket 2S000170.*



**COVER STRUMENTI  
IN ALLUMINIO SATINATO  
SATIN-FINISHED ALUMINIUM  
TOOLS COVER**

.....  
COD. 606181M

Mostrina in alluminio satinato a mano, sostituisce la parte di produzione verniciata nera. Solo per V7 II.

*Hand satin-finished aluminium panel, replacing the black painted production part. Only for V7 II.*



**MANUBRIO NERO  
BLACK HANDLEBAR**

.....  
COD. 2S000173

Manubrio nero, per una personalizzazione esclusiva della propria V7.

*Black handlebar for a an exclusive V7 customising.*



**CUPOLINO  
TOP FAIRING**

.....  
COD. 886995

Il kit comprende il cupolino in materiale plastico stampato (al grezzo) e i supporti in alluminio con relativa viteria.

*The kit includes a plastic moulded top fairing (unfinished) and the aluminium brackets with relative nuts and bolts.*



**KIT SUPPORTO CENTRALINA GMP  
GMP INSTALLATION KIT**

.....  
COD. 2S000170

Kit supporto dedicato al fissaggio del GMP, non necessita di cablaggi in quanto già predisposti nella moto.

*Dedicated bracket kit for fastening the GMP, does not require wiring harness since it is already provided on the motorcycle.*



**SEMIMANUBRI CROMATI  
CHROMED SEMI-HANDLEBAR**

.....  
COD. 2S000176

Kit di semimanubri cromati, completo di cavi e tubi per versione ABS, per cambiare l'impostazione della tua V7 in qualcosa di ancora più sportivo

*Kit of chromed semi-handlebars, complete with cables and tubes for ABS version, to change the setting of your V7 into something even more sporty*



**KIT COPERCHIO INIETTORI  
INJECTOR COVERS KIT**

.....  
COD. 886996

La coppia di coperchi iniettori permette di proteggere questi ultimi dal contatto accidentale con le ginocchia del guidatore.

*The injector covers protects them against accidental contact with the driver's knees.*





**FIANCATINE IN ALLUMINIO  
ALUMINIUM SIDE FAIRINGS**

.....  
COD. 886994

Le fiancattine in alluminio spazzolato e anodizzato rendono V7 ancora più bella: ne snelliscono i fianchi e richiamano le creazioni artigianali tipiche delle gare per derivate di serie degli anni 70.

*The brushed and anodized aluminium fairings make your V7 even more attractive: they slim down the sides and are reminiscent of the hand crafted creations which were typical of factory derivative series in the 70's.*



**PROTEZIONI SERBATOIO  
TANK PROTECTION**

.....  
COD. 897021

Coppia di paraginocchia adesivi in morbida gomma da applicare ai lati del serbatoio, caratterizzati da un disegno a rombi e impreziositi dal logo Moto Guzzi.

*Adhesive soft rubber knee pads to be applied on the tank sides, with rhombus design and enriched with the Moto Guzzi logo.*



**SELLA COMFORT GEL  
COMFORT GEL SADDLE**

.....  
COD. B063597

Sella biposto con inserti in gel nelle zone pilota e passeggero. Oltre al comfort, offre un maggior appoggio a terra grazie al diverso disegno dello schiumato.

Logo "Comfort Gel" punzonato.

*Two seat saddle with gel inserts in the driver and passenger area. Besides comfort, it offers better contact with ground due to the different design of the foamed structure. Punched "Comfort Gel" logo.*



**SELLA RIBASSATA COMFORT GEL  
LOWER COMFORT GEL SADDLE**

.....  
COD. B063598

Biposto, unisce il comfort del gel alla comodità del profilo rivisto e ribassato, per consentire al pilota un migliore e più sicuro appoggio a terra. Logo "Comfort Gel" punzonato.

*Two-seated, combines the comfort given by the gel with the revised and lowered profile, to allow the driver to have a better and safer contact with the ground. Punched "Comfort Gel" logo.*



**COPRISERBATOIO CON BORSELLO  
TANK COVER WITH POCKET**

.....  
COD. B063837

Realizzato in pelle con trattamento antiacqua, offre una comoda tasca portaoggetti e portadocumenti poco ingombrante.

*Made of leather with waterproof treatment, it offers a convenient object holder pocket and small document carrier.*



**BORSA CON COPRISERBATOIO  
TANKBAG WITH TANK COVER**

.....  
COD. B063838

Borsa serbatoio in nylon e vera pelle idrorepellente, dotata di 2 tasche laterali e una superiore portacartina. Si fissa tramite agganci rapidi al copriserbatoio, che può restare montato sul serbatoio grazie al foro per il rifornimento ed è facilmente sganciabile e trasportabile grazie alla pratica maniglia.

*Waterproof tank bag in nylon and leather, equipped with 2 side pockets and a top map holder. It is fastened by means of quick couplings to the tank cover and stays mounted on the tank thanks to the refuelling hole, being easily detachable and carried using the practical handle.*



**PEDANE PILOTA IN ALLUMINIO  
PILOT ALUMINIUM FOOTPEGS**

.....  
COD. 2S000168

Pedane anteriori in alluminio, alleggerite e dalla linea sportiva, accentuano lo spirito racing della V7.

*Front aluminium footpegs, lightened and of the sportive line, they highlight the racing spirit of the V7.*



**PEDANE PASSEGGERO IN ALLUMINIO  
PASSENGER ALUMINIUM FOOTPEGS**

.....  
COD. 2S000169

Pedane posteriori in alluminio, alleggerite e dalla linea sportiva, accentuano lo spirito racing della V7.

*Rear aluminium footpegs, lightened and of the sportive line, they highlight the racing spirit of the V7.*





**PEDANE ARRETRATE  
RACING FOOTRESTS**

.....  
COD. 886954

Le pedane arretrate garantiscono una posizione di guida più sportiva e sono l'ideale complemento dei semimanubri che equipaggiano le café racers.

*The swept back pedals guarantee a more sportive driving position, being the ideal complement of the semi-handlebars provided on the café racers.*



**KIT SUPPORTO USB  
USB SOCKET KIT**

.....  
COD. 2S000166

Presse USB fornita di supporto dedicato per installazione nel sottosella, per la ricarica dei supporti elettronici, non consente il dialogo con gli apparati elettronici del mezzo.

*USB socket with bracket for installation under the saddle, to recharge the electronic media, does not allow dialogue with the electronic devices of the vehicle.*



**MOLLE AMMORTIZZATORI ROSSE  
RED SHOCK ABSORBER SPRINGS**

.....  
COD. 2S000175

Molle di colore rosso da sostituire a quelle nere negli ammortizzatori di serie della V7 II.

*Red springs to replace the black ones in the V7 II series shock absorbers.*



**BORSA BAULETTO  
REAR TOPBAG**

.....  
COD. 983308

Borsa bauletto in vera pelle idrorepellente, si fissa al portapacchi dedicato tramite comode cinghie e può essere facilmente asportata grazie alla maniglia posteriore.

*Water repellent top box bag made of true leather, mounted to the dedicated luggage carrier with practical straps, can be easily detached thanks to its rear handle.*



**KIT BUSSE FORATE  
DRILLED BUSHING KIT**

.....  
COD. 2S000172

Tre busse forate, per migliorare l'estetica della V7, si applicano in corrispondenza degli attacchi degli ammortizzatori.

*Three drilled bushings to improve the look of the V7, applied in correspondence with the shock absorber fittings.*



**AMMORTIZZATORI PERFORMANCE  
PERFORMANCE SHOCK ABSORBER**

.....  
COD. 897773 NERO/BLACK  
COD. 606091M ROSSO/RED

Con serbatoio gas separato, regolabili in estensione, compressione e precarico, migliorano comfort e guidabilità grazie alle eccezionali caratteristiche tecniche che li contraddistinguono.

*With separate gas tank, adjustable in size, compression and preload, improved comfort and handling thanks to exceptional technical features that distinguish them.*



**BORSE LATERALI  
SIDE BAGS**

.....  
COD. 983162

Kit composto dalla coppia di valigie rigide in nylon, del volume di circa 20 litri, rivestite in vera pelle idrorepellente e dotate di chiusura con fibbia in acciaio cromato, telaio di fissaggio in acciaio ad alta resistenza e coppia di borse interne asportabili in nylon. NB: solo per versione Classic.

*Kit composed of a pair of nylon rigid cases, of around 20 litres capacity, coated with chromed steel buckle closing system, high-resistance steel clamping frame and internal detachable nylon bags. NOTE: Only for Classic version.*



**VALIGIE SEMIRIGIDE  
COMPLETE DI SUPPORTI  
SEMI-RIGID PANNIERS KIT  
WITH BRACKETS**

.....  
COD. B063096

Valigie semirigide in poliestere complete di cuffie anti-pioggia termosaldate, dotate di sistema di aggancio/sgancio rapido Fast Click. Necessitano di portapacchi.

*Semi-rigid cases made of polyester complete with thermoformed rain over, equipped with hook/quick release system Fast Click. Require luggage carriers.*





**PORTAPACCHI  
REAR RACK**

.....  
COD. 983163

Realizzato in acciaio cromato, si fissa al posto delle maniglie passeggero, che sostituisce grazie all'ampio maniglione integrato.

*Made of chromed steel, it is mounted in place of the passenger handle that it replaces thanks to the large integrated handle.*



**TELO COPRIMOTO "EAGLE"  
"EAGLE" BIKE COVER**

.....  
COD. 606028M0001

Telo su misura da interno per la protezione dalla polvere da utilizzare durante le soste in garage della moto. È realizzato in un tessuto elasticizzato con grafica speciale.

*Tailor-made motorcycle cover for inside to protect against dust, intended for use during long periods of storing the bike in a garage. It is made of stretch fabric with special graphics.*



**KIT RECORD  
RECORD KIT**

.....  
COD. 606179M  
CUPOLINO ANTERIORE/FRONT FAIRING  
COD. 606180M CODONE SELLA/TAIL SEAT

Disegnato dal centro Stile Moto Guzzi, richiama le forme aerodinamiche delle racer anni '70 ed è realizzata in vetroresina. Il kit si compone di un cupolino anteriore tondeggiante (cod. 606179M) che incorpora il faro singolo centrale della V7, completato da due profili laterali che raccordano la carenatura alla zona serbatoio. La sella viene invece sostituita da un unico elemento (cod. 606180M) che incorpora anche il codone, sagomato a formare uno spoiler nella sua parte terminale. La seduta sportiva è realizzata in uno speciale materiale schiumato bicomponente, ignifugo ed idrorepellente con memoria di forma, il massimo della tecnologia di diretta derivazione agonistica. Il kit è comprensivo dello staffaggio anteriore in acciaio tagliato al laser e sabbato e rispetta i criteri omologativi vigenti. È necessario montare i semimanubri.

*Designed by the Moto Guzzi Style Centre, it echoes the aerodynamic shapes of the '70s racer vehicles and it is made of fibreglass. The kit consists of a roundish front top fairing (cod. 606179M) that incorporates the single central headlamp of V7, completed by two side profiles which connect the fairing to the tank area. The saddle is replaced by a single element (cod. 606180M) which also includes the tail, shaped to form a spoiler in the tail. The sport saddle is made in a special two-component, fire and waterproof memory foam material, the best technology directly from the sport world. The kit includes the front clamping made in laser-cut sanded steel, and meets the approval requirements. Mounting requires Semi-handlebars.*



**TELO COPRIMOTO "SHAPE"  
"SHAPE" BIKE COVER**

.....  
COD. 606028M0002

Telo su misura da interno per la protezione dalla polvere da utilizzare durante le soste in garage della moto. È realizzato in un tessuto elasticizzato con grafica speciale.

*Tailor-made motorcycle cover for inside to protect against dust, intended for use during long periods of storing the bike in a garage. It is made of stretch fabric with special graphics.*



**TELO COPRIMOTO V7  
V7 BIKE COVER**

.....  
COD. 895729

Telo su misura da interno per la protezione dalla polvere da utilizzare durante le soste in garage della moto. È realizzato in un tessuto elasticizzato con grafica speciale.

*Tailor-made motorcycle cover for inside to protect against dust, intended for use during long periods of storing the bike in a garage. It is made of stretch fabric with special graphics.*



V7 II

RACER







**GUZZI MULTIMEDIA PLATFORM**  
**GUZZI MULTIMEDIA PLATFORM**

.....  
 COD. 2S000157

GMP è il nuovo dispositivo che consente di collegare il proprio Smartphone alla moto, trasformandola in una vera e propria piattaforma multimediale. Per l'installazione utilizzare il supporto dedicato 2S000170.

*GMP is the new device that allows you to connect your smartphone to the motorcycle, turning it to a real multimedia platform. To mount it, use the dedicated bracket 2S000170.*



**KIT SUPPORTO USB**  
**USB SOCKET KIT**

.....  
 COD. 2S000166

Presca USB fornita di supporto dedicato per installazione nel sottosella, per la ricarica dei supporti elettronici, non consente il dialogo con gli apparati elettronici del mezzo.

*USB socket with bracket for installation under the saddle, to recharge the electronic media, does not allow dialogue with the electronic devices of the vehicle.*



**COPRISERBATOIO CON BORSELLO**  
**TANK COVER WITH POCKET**

.....  
 COD. B063837

Realizzato in pelle con trattamento antiacqua, offre una comoda tasca portaoggetti e portadocumenti poco ingombrante.

*Made of leather with waterproof treatment, it offers a convenient object holder pocket and small document carrier.*



**BORSA CON COPRISERBATOIO**  
**TANKBAG WITH TANK COVER**

.....  
 COD. B063838

Borsa serbatoio in nylon e vera pelle idrorepellente, dotata di 2 tasche laterali e una superiore portacartina. Si fissa tramite agganci rapidi al copriserbatoio, che può restare montato sul serbatoio grazie al foro per il rifornimento ed è facilmente sganciabile e trasportabile grazie alla pratica maniglia.

*Waterproof tank bag in nylon and leather, equipped with 2 side pockets and a top map holder. It is fastened by means of quick couplings to the tank cover and stays mounted on the tank thanks to the refuelling hole, being easily detachable and carried using the practical handle.*



**KIT SUPPORTO CENTRALINA GMP**  
**GMP INSTALLATION KIT**

.....  
 COD. 2S000170

Kit supporto dedicato al fissaggio del GMP, non necessita di cablaggi in quanto già predisposti nella moto.

*Dedicated bracket kit for fastening the GMP, does not require wiring harness since it is already provided on the motorcycle.*



**PROTEZIONI SERBATOIO**  
**TANK PROTECTION**

.....  
 COD. 897021

Coppia di paraginocchia adesivi in morbida gomma da applicare ai lati del serbatoio, caratterizzati da un disegno a rombi e impreziositi dal logo Moto Guzzi.

*Adhesive soft rubber knee pads to be applied on the tank sides, with rhombus design and enriched with the Moto Guzzi logo.*



**SELLA COMFORT GEL**  
**COMFORT GEL SADDLE**

.....  
 COD. B063597

Sella biposto con inserti in gel nelle zone pilota e passeggero. Oltre al comfort, offre un maggior appoggio a terra grazie al diverso disegno dell'imbottitura. Logo "Comfort Gel" punzonato.

*Two seat saddle with gel inserts in the driver and passenger area. Besides comfort, it offers better contact with ground due to the different design of the foamed structure. Punched "Comfort Gel" logo.*



**SELLA RIBASSATA COMFORT GEL**  
**LOWER COMFORT GEL SADDLE**

.....  
 COD. B063598

Biposto, unisce il comfort del gel alla comodità del profilo rivisto e ribassato, per consentire al pilota un migliore e più sicuro appoggio a terra. Logo "Comfort Gel" punzonato.

*Two-seated, combines the comfort given by the gel with the revised and lowered profile, to allow the driver to have a better and safer contact with the ground. Punched "Comfort Gel" logo.*



**KIT BIPOSTO  
TWO-SEATER KIT**

.....  
COD. 886870

Il kit è composto dalla sella biposto di serie sulla versione Stone/Special ma in una versione specifica con diverso rivestimento e cuciture, dalle pedane passeggero complete e dalle maniglie.

*The kit consists of the two-seats factory saddle on the Stone/Special version, but in a specific version with different finishing and stitching, complete passenger footpegs and handles.*



**BORSA BAULETTO  
REAR TOPBAG**

.....  
COD. 983308

Borsa bauletto in vera pelle idrorepellente, si fissa al portapacchi dedicato tramite comode cinghie e può essere facilmente asportata grazie alla maniglia posteriore.

*Water repellent top box bag made of true leather, mounted to the dedicated luggage carrier with practical straps, can be easily detached thanks to its rear handle.*



**TELO COPRIMOTO "SHAPE"  
"SHAPE" BIKE COVER**

.....  
COD. 606028M0002

Telo su misura da interno per la protezione dalla polvere da utilizzare durante le soste in garage della moto. È realizzato in un tessuto elasticizzato con grafica speciale.

*Tailor-made motorcycle cover for inside to protect against dust, intended for use during long periods of storing the bike in a garage. It is made of stretch fabric with special graphics.*



**KIT RECORD  
RECORD KIT**

.....  
COD. 606179M  
CUPOLINO ANTERIORE/FRONT FAIRING  
COD. 606180M CODONE SELLA/TAIL SEAT

Disegnato dal centro Stile Moto Guzzi, richiama le forme aerodinamiche delle racer anni '70 ed è realizzata in vetroresina. Il kit si compone di un cupolino anteriore tondeggianti (cod. 606179M) che incorpora il faro singolo centrale della V7, completato da due profili laterali che raccordano la carenatura alla zona serbatoio. La sella viene invece sostituita da un unico elemento (cod. 606180M) che incorpora anche il codone, sagomato a formare uno spoiler nella sua parte terminale. La seduta sportiva è realizzata in uno speciale materiale schiumato bicomponente, ignifugo ed idrorepellente con memoria di forma, il massimo della tecnologia di diretta derivazione agonistica. Il kit è comprensivo dello staffaggio anteriore in acciaio tagliato al laser e sabbiato e rispetta i criteri omologativi vigenti. È necessario montare i semimanubri.

*Designed by the Moto Guzzi Style Centre, it echoes the aerodynamic shapes of the '70s racer vehicles and it is made of fibreglass. The kit consists of a roundish front top fairing (cod. 606179M) that incorporates the single central headlamp of V7, completed by two side profiles which connect the fairing to the tank area. The saddle is replaced by a single element (cod. 606180M) which also includes the tail, shaped to form a spoiler in the tail. The sport saddle is made in a special two-component, fire and waterproof memory foam material, the best technology directly from the sport world. The kit includes the front clamping made in laser-cut sanded steel, and meets the approval requirements. Mounting requires Semi-handlebars.*



**PORTAPACCHI  
REAR RACK**

.....  
COD. 887001

Realizzato in acciaio cromato, si monta sia in configurazione monoposto che con sella biposto.

*made of chrome steel, it is mounted either in one seat configuration and on two seat saddles.*



**TELO COPRIMOTO "EAGLE"  
"EAGLE" BIKE COVER**

.....  
COD. 606028M0001

Telo su misura da interno per la protezione dalla polvere da utilizzare durante le soste in garage della moto.

È realizzato in un tessuto elasticizzato con grafica speciale. *Tailor-made motorcycle cover for inside to protect against dust, intended for use during long periods of storing the bike in a garage. It is made of stretch fabric with special graphics.*



**TELO COPRIMOTO V7  
V7 BIKE COVER**

.....  
COD. 895729

Telo su misura da interno per la protezione dalla polvere da utilizzare durante le soste in garage della moto.

È realizzato in un tessuto elasticizzato con grafica speciale. *Tailor-made motorcycle cover for inside to protect against dust, intended for use during long periods of storing the bike in a garage. It is made of stretch fabric with special graphics.*



Il fascino di personalizzare una Moto Guzzi V7 Stone o Special in sintonia con il proprio stile. Il Garage come ambiente di lavoro, un territorio di scambio di esperienze, una fucina di idee per gli amanti del custom. Uno spazio dove nascono modelli unici come le proprie storie.

*The charm of personalising a Moto Guzzi V7 Stone or Special in sync with your own style. The Garage as a work environment, an experience swapping territory, a mine of ideas for custom enthusiasts. A space where models as unique as their history are born.*







  
**MOTO GUZZI®**

**ACCESSORI**  
**ACCESSORIES**

  
**DAPPER**  
**STYLE**

**RIDE THE STYLE**





**TABELLE IN ALLUMINIO LUCIDATO  
POLISHED ALUMINIUM  
NUMBERPLATES**

.....  
COD. 2S000148

Tre tabelle portanumero, una frontale e due laterali montate su fianchetti anodizzati neri, in alluminio naturale lucidato a mano e con relativi sostegni.

*Three numberplates, one front and two sides, mounted on black anodized side panels, are made in hand-polished natural aluminium, with specific supports.*



**SERBATOIO CROMATO  
CHROMED TANK**

.....  
COD. 606007M  
COD. 606133M USA

Serbatoio in metallo cromato, in abbinamento agli altri elementi in alluminio lucidato costituisce il modo migliore per dare alla tua V7 un Look "Dapper" davvero completo.

*Chromed metal tank, in combination with the other elements made in polished aluminium, is the best way to give Your V7 a complete "Dapper" look.*



**PROTEZIONI SILENZIATORE  
ALLUMINIO LUCIDATO  
SILENCER GUARDS**

.....  
COD. 2S000150

Coppia di protezioni in alluminio naturale lucidato a mano, per scarichi di serie. Con un design più stiloso, mantengono la funzione di protezione delle gambe dal contatto con lo scarico.

*Hand-polished guards set in natural aluminium, for standard exhausts. With a more stylish design, maintaining the protective function for the legs from contact with the exhaust.*



**SEMIMANUBRI CROMATI  
CHROMED SEMI-HANDLEBAR**

.....  
COD. 2S000176

Kit di semimanubri cromati, completo di cavi e tubi per versione ABS, per cambiare l'impostazione della tua V7 in qualcosa di ancora più sportivo.

*Kit of chromed semi-handlebars, complete with cables and tubes for ABS version, to change the setting of your V7 into something even more sporty*



**PARAFANGHI ALLUMINIO  
LUCIDATO  
POLISHED ALUMINIUM  
MUDGUARDS**

.....  
COD. 2S000147

Parafanghi in alluminio naturale lucidato a mano, a mano, danno un vantaggio in termini di peso rispetto ai componenti di serie.

*Hand polished natural aluminium mudguards, give a weight advantage in comparison with original equipment.*



**COPRI INIETTORI  
IN ALLUMINIO LUCIDATO  
POLISHED INJECTORS COVERS**

.....  
COD. 2S000149

Coppia di copri iniettori in alluminio naturale lucidato a mano, variante estetica dei copri iniettori di serie, da abbinare agli altri elementi lucidati per completare il look grintoso della tua V7.

*Pair of hand-polished natural aluminium injectors covers, aesthetic variant of factory injectors covers, to be combined with the other polished elements to complete the Sporty look of the V7.*



**SEMIMANUBRI NERI  
BLACK SEMI-HANDLEBARS**

.....  
COD. B063843

Kit di semimanubri completamente neri, completo di cavi e tubi, per cambiare l'impostazione della tua V7 in qualcosa di ancora più sportivo. Specifici per la versione senza ABS bicorpo.

*Kit of black semi-handlebars, complete with cables and tubes to change the setting of the V7 into something even more sporty. Specifications for the version without ABS and two throttle body.*



**SEMIMANUBRI NERI  
BLACK SEMI-HANDLEBARS**

.....  
COD. 606220M

Kit di semimanubri completamente neri, completo di cavi e tubi, per cambiare l'impostazione della tua V7 in qualcosa di ancora più sportivo. Specifici per la versione senza ABS monocorpo.

*Kit of black semi-handlebars, complete with cables and tubes to change the setting of the V7 into something even more sporty. Specifications for the version without ABS and single throttle body.*





**SPECCHI MANUBRIO  
HANDLEBAR MIRRORS**

.....  
COD. 2S000261

Specchietti da manubrio, sostituiscono quelli di serie. Omologati ECE, in alluminio, con snodi lenticolari e viti in acciaio inox. Si fissano al manubrio e fanno anche da paramani, lasciando la parte riflettente nella stessa posizione di quelli di serie.

*Handlebars mirrors, in replacement of factory one ECE approved, in aluminium, with lenticular ball joints and stainless steel screws. Fixed to handlebars ends, they also make the function of handguards leaving the reflective part in the same position as the factory ones.*



**SELLA MONOPOSTO  
SINGLE-SEAT SADDLE**

.....  
COD. 606124M

Sella sportiva monoposto, basata sulla linea della classica V7 Café.

*Single-seat sport saddle based on the classic V7 Café line.*



**BORSA LATERALE CUOIO NERO  
BLACK LEATHER SIDE BAG**

.....  
COD. 2S000296 SINISTRA/LEFT  
COD. 2S000297 DESTRA/RIGHT

Borsa di cuoio naturale finito con una conca vegetale da agganciare sui lati della parte posteriore della tua V7. Si fissa ai telaietti specifici 2S000280 (sinistra) e 2S000294 (destra), da acquistare separatamente.

*Natural leather bag finished with a vegetable tan to be mounted on the rear sides of your V7. It is fixed to the specific subframes 2S000280 (left) and 2S000294 (right), to be purchased separately.*

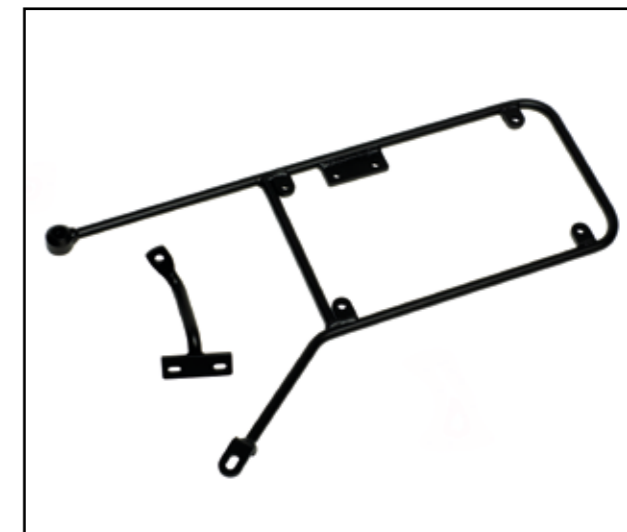

**TELAIETTO PER BORSA LATERALE  
SIDE BAG SUBFRAME**

.....  
COD. 2S000280 SINISTRA/LEFT  
COD. 2S000294 DESTRA/RIGHT

Supporto di metallo, necessario per fissare la borsa laterale sinistra in cuoio naturale 2S000264 o in cuoio nero 2S000296.

*Metal support, necessary to secure the left side bag in natural leather 2S000264 or black leather 2S000296.*



**SELLA MONOPOSTO PREMIUM  
PREMIUM SINGLE-SEAT SADDLE**

.....  
COD. 2S000260

Sella sportiva monoposto, caratterizzata da imbottiture elettrosaldate e cucite. Logo Moto Guzzi ricamato.

*Single-seat sport saddle with electro-welded and stitched padding. Moto Guzzi Logo embroidered.*



**BORSA LATERALE CUOIO NATURALE  
NATURAL LEATHER SIDE BAG**

.....  
COD. 2S000264 SINISTRA/LEFT  
COD. 2S000295 DESTRA/RIGHT

Borsa di cuoio naturale finito con una conca vegetale da agganciare sui lati della parte posteriore della tua V7. Si fissa ai telaietti specifici 2S000280 (sinistra) e 2S000294 (destra), da acquistare separatamente.

*Natural leather bag finished with a vegetable tan to be mounted on the rear sides of your V7. It is fixed to the specific subframes 2S000280 (left) and 2S000294 (right), to be purchased separately.*



**BORSA PORTA ATTREZZI NERA  
BLACK LEATHER TOOLS BAG**

.....  
COD. 605989M

Borsa portatutto in cuoio nero finito con una conca vegetale, agganciabile sul portapacchi o sul serbatoio (con l'apposita fascia dello stesso colore). La borsa è resistente all'acqua e non ha bisogno di cure particolari.

*A carry-all bag in black leather finished with a vegetable tan, can be attached to the luggage rack or fuel tank (with the appropriate band of the same colour). The bag is water resistant and does not need special care.*



**BORSA PORTA ATTREZZI MARRONE  
BROWN LEATHER TOOLS BAG**

.....  
COD. 605991M

Borsa portatutto in cuoio naturale finito con una conca vegetale, agganciabile sul portapacchi o sul serbatoio (con l'apposita fascia dello stesso colore). La borsa è resistente all'acqua e non ha bisogno di cure particolari.

*A carry-all bag in brown leather finished with a vegetable tan, can be attached to the luggage rack or fuel tank (with the appropriate band of the same colour). The bag is water resistant and does not need special care.*





**SUPPORTO TARGA  
LICENCE PLATE HOLDER**

.....  
COD. 2S000282  
COD. 2S000500 USA

Sostegno ad arco per la targa, da utilizzare in caso di montaggio del parafrangente in alluminio, prevede il fissaggio del gruppo ottico posteriore di serie.

*Bracket support for the plate, to be used in case of Aluminium rear mudguard, is developed to allow the use of factory taillights.*



**SUPPORTI FRECCE  
TURN INDICATOR BRACKETS**

.....  
COD. 2S000266

Supporti in alluminio per montare le frecce posteriori nel caso di adozione del supporto porta targa 2S000282 per parafrangenti in alluminio. Utilizzando questi supporti, che avvicinano gli indicatori di direzione alla sella, si rende la vista posteriore della moto più leggera e filante.

*Aluminium mounting brackets for the factory rear turn indicators if a license plate bracket for 2S000282 aluminium mudguards is used. Using these brackets, these bring the turn indicators closer to the saddle, leaving the rear more free to express all the style.*



**NUMERI ADESIVI  
ADHESIVE NUMBERS**

.....  
COD. 605983M

Il numero di Omobono "The Black Devil" Tenni, uno dei più grandi piloti della storia. Da mettere sulle tabelle frontali e laterali per viaggiare ricordando un eroe dalla storia Moto Guzzi.

*Omobono "The Black Devil" Tenni's number, one of the greatest riders in history. To be applied on front and sides numberplates to remember a Moto Guzzi Legend*





  
**MOTO GUZZI®**

**ACCESSORI  
ACCESSORIES**



**STYLE**

**URBAN NIGHT**







**CUPOLINO VERNICIATO NERO  
BLACK PAINTED ALUMINIUM  
TOP FAIRING**

.....  
COD. 2S000178

Cupolino in alluminio verniciato fissato al corpo con supporti di acciaio inossidabile. Per donare alla tua V7 uno sguardo unico.

*Painted aluminium top fairing fixed to the body with stainless steel brackets. To give your V7 a unique look.*



**PARAFANGHI IN ALLUMINIO NERI  
BLACK PAINTED ALUMINIUM  
MUDGUARDS**

.....  
COD. 2S000180

Parafanghi in alluminio alleggeriti, verniciati in nero, per completarne il look total black dal primo all'ultimo centimetro.

*Lightweight aluminium mudguards, painted the same black as the V7 to complete the total black look from the first to the last centimeter.*



**SEMIMANUBRI CROMATI  
CHROMED SEMI-HANDLEBAR**

.....  
COD. 2S000176

Kit di semimanubri cromati, completo di cavi e tubi per versione ABS, per cambiare l'impostazione della tua V7 in qualcosa di ancora più sportivo.

*Kit of chromed semi-handlebars, complete with cables and tubes for ABS version, to change the setting of your V7 into something even more sporty.*



**SEMIMANUBRI NERI  
BLACK SEMI-HANDLEBARS**

.....  
COD. B063843

Kit di semimanubri completamente neri, completo di cavi e tubi, per cambiare l'impostazione della tua V7 in qualcosa di ancora più sportivo. Specifici per la versione senza ABS bicorpo.

*Kit of black semi-handlebars, complete with cables and tubes to change the setting of the V7 into something even more sporty. Specifications for the version without ABS and two throttle body.*



**FIANCHETTI IN ALLUMINIO NERI  
BLACK PAINTED ALUMINIUM  
SIDE PANELS**

.....  
COD. 2S000179

Fianchetti laterali completamente neri, per offrire alla tua V7 una superficie ininterrotta, sinuosa e perfetta.

*Completely lighted, aluminium, black painted side panels to complete the black look from the first to the last centimeter.*



**SERBATOIO VERNICIATO NERO  
BLACK FUEL TANK**

.....  
COD. 606026M  
COD. 606132M USA

Serbatoio nero verniciato nello stesso colore dei particolari in alluminio della V7, per completare il look total black dal primo all'ultimo centimetro.

*Fuel tank painted in the same Black color of the other aluminium parts of the V7 to complete the total black look from the first to the last centimeter.*



**SEMIMANUBRI NERI  
BLACK SEMI-HANDLEBARS**

.....  
COD. 606220M

Kit di semimanubri completamente neri, completo di cavi e tubi, per cambiare l'impostazione della tua V7 in qualcosa di ancora più sportivo. Specifici per la versione senza ABS monocorpo.

*Kit of black semi-handlebars, complete with cables and tubes to change the setting of the V7 into something even more sporty. Specifications for the version without ABS and single throttle body.*



**SPECCHI MANUBRIO  
HANDLEBAR MIRRORS**

.....  
COD. 2S000261

Specchietti da manubrio, sostituiscono quelli di serie. Omologati ECE, in alluminio, con snodi lenticolari e viti in acciaio inox. Si fissano al manubrio e fanno anche da paramani, lasciando la parte riflettente nella stessa posizione di quelli di serie.

*Handlebars mirrors, in replacement of factory one ECE approved, in aluminium, with lenticular ball joints and stainless steel screws. Fixed to handlebars ends, they also make the function of handguards leaving the reflective part in the same position as the factory ones.*





**SELLA AD UN POSTO E MEZZO  
ONE AND A HALF SEAT SADDLE**

.....  
COD. 2S000265

Sella con seduta ridotta rispetto a quella di serie montata sulla moto. Perfetta per guidare in una posizione più aerodinamica e anche per permetterti, quando serve, di portare una persona. Logo Moto Guzzi ricamato.

*Smaller saddle for your V7 than the one that is factory mounted on the bike. Smaller saddle perfect for riding in a more aerodynamic position as well as for allowing to host a passenger in case of need. Moto Guzzi Logo embroidered.*



**BORSA LATERALE CUIO NATURALE  
NATURAL LEATHER SIDE BAG**

.....  
COD. 2S000264 SINISTRA/LEFT  
COD. 2S000295 DESTRA/RIGHT

Borsa di cuoio naturale finito con una concia vegetale da agganciare sui lati della parte posteriore della tua V7. Si fissa ai telaietti specifici 2S000280 (sinistra) e 2S000294 (destra), da acquistare separatamente.

*Natural leather bag finished with a vegetable tan to be mounted on the rear sides of your V7. It is fixed to the specific subframes 2S000280 (left) and 2S000294 (right), to be purchased separately.*



**BORSA PORTA ATTREZZI NERA  
BLACK LEATHER TOOLS BAG**

.....  
COD. 605989M

Borsa portatutto in cuoio nero finito con una concia vegetale, agganciabile sul portapacchi o sul serbatoio (con l'apposita fascia dello stesso colore). La borsa è resistente all'acqua e non ha bisogno di cure particolari.

*A carry-all bag in black leather finished with a vegetable tan, can be attached to the luggage rack or fuel tank (with the appropriate band of the same colour). The bag is water resistant and does not need special care.*



**BORSA PORTA ATTREZZI MARRONE  
BROWN LEATHER TOOLS BAG**

.....  
COD. 605991M

Borsa portatutto in cuoio naturale finito con una concia vegetale, agganciabile sul portapacchi o sul serbatoio (con l'apposita fascia dello stesso colore). La borsa è resistente all'acqua e non ha bisogno di cure particolari.

*A carry-all bag in brown leather finished with a vegetable tan, can be attached to the luggage rack or fuel tank (with the appropriate band of the same colour). The bag is water resistant and does not need special care.*



**BORSA LATERALE CUIO NERO  
BLACK LEATHER SIDE BAG**

.....  
COD. 2S000296 SINISTRA/LEFT  
COD. 2S000297 DESTRA/RIGHT

Borsa di cuoio naturale finito con una concia vegetale da agganciare sui lati della parte posteriore della tua V7. Si fissa ai telaietti specifici 2S000280 (sinistra) e 2S000294 (destra), da acquistare separatamente.

*Natural leather bag finished with a vegetable tan to be mounted on the rear sides of your V7. It is fixed to the specific subframes 2S000280 (left) and 2S000294 (right), to be purchased separately.*

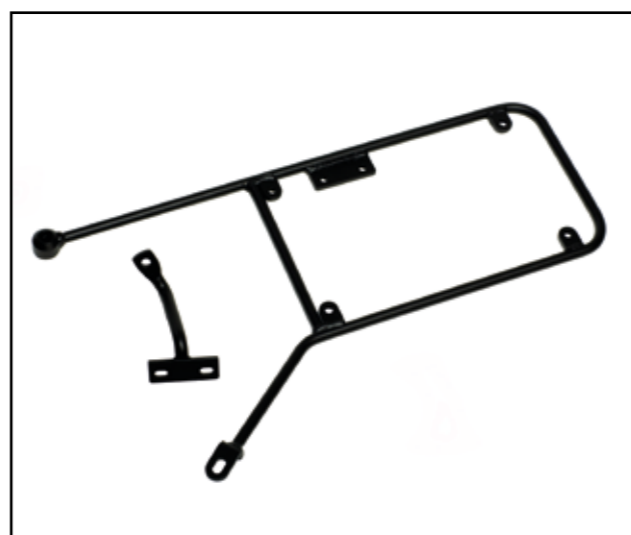

**TELAIETTO PER BORSA LATERALE  
SIDE BAG SUBFRAME**

.....  
COD. 2S000280 SINISTRA/LEFT  
COD. 2S000294 DESTRA/RIGHT

Supporto di metallo, necessario per fissare la borsa laterale sinistra in cuoio naturale 2S000264 o in cuoio nero 2S000296.

*Metal support, necessary to secure the left side bag in natural leather 2S000264 or black leather 2S000296.*



**SUPPORTO TARGA  
LICENCE PLATE HOLDER**

.....  
COD. 2S000282  
COD. 2S000500 USA

Sostegno ad arco per la targa, da utilizzare con i parafanghi in alluminio gruppo ottico di serie.

*Bracket support for the plate, to be used with aluminium mudguards and the factory taillight assembly.*



**SUPPORTI FRECCHE  
TURN INDICATOR BRACKETS**

.....  
COD. 2S000266

Supporti in alluminio per montare le frecce posteriori nel caso di adozione del supporto porta targa 2S000282 per parafanghi in alluminio. Avvicinando gli indicatori di direzione alla sella, lasciano il posteriore più libero di esprimere tutto lo stile.

*Aluminium mounting brackets for the factory rear turn indicators if a license plate bracket for 2S000282 aluminium mudguards is used. These bring the turn indicators closer to the saddle, leaving the rear more free to express all the style.*



  
**MOTO GUZZI®**

**ACCESSORI  
ACCESSORIES**



**STYLE**



**REBEL INSIDE**





**TABELLE IN ALLUMINIO SATINATO  
SATIN ALUMINIUM NUMBER PLATES**  
.....  
COD. 2S000153

Tabelle portanumero in alluminio satinato a mano, due laterali e una frontale, con relativi supporti.  
Per completare il look classico della V7.

*Numberplates kit in hand-finished satin aluminium, with specific mounting brackets.  
To complete the classic look of your V7.*



**COPRI INIETTORI  
IN ALLUMINIO SATINATO  
SATIN ALUMINIUM INJECTOR  
COVERS**  
.....  
COD. 2S000154

Coppia di copri iniettori in alluminio naturale satinato a mano, da abbinare agli altri elementi satinati per completare il look della V7.

*Two injector covers in hand-finished natural satin aluminium to replace the factory ones and to make your V7 even more elegant.*



**PEDANE OFF ROAD PILOTA  
OFF ROAD FOOTPEG KIT**  
.....  
COD. 2S000258

Kit di pedane pensate appositamente per l'utilizzo offroad. Consentono di non perdere l'appoggio anche nelle condizioni fuoristrada.

*Footpegs kit for your V7 designed specifically for offroad use. They will help you not to lose solid footing even in off road conditions.*



**ESTENSIONE PEDANA  
IN ALLUMINIO LAVORATO  
ALUMINIUM FOOTPEG EXTENSION**  
.....  
COD. 2S000320

Da applicare alle pedane offroad 2S000258 nel caso di utilizzo dello scarico 2S000311 e 2S000313. Il codice corrisponde ad una estensione pedana: è necessario ordinare due pezzi.

*To be mounted on the offroad footpeg 2S000258 in case of use of exhaust 2S000311 and 2S000313. The code corresponds to one footpeg only: two pieces must be ordered.*



**PARAFANGHI ALLUMINIO  
SATINATO  
LONG SATIN ALUMINIUM  
MUDGUARDS**  
.....  
COD. 2S000152

Parafanghi lunghi in alluminio naturale, satinato a mano e di peso ridotto rispetto a quelli tradizionali.

*Natural aluminium long mudguards, satin finished by hand and lighter than the conventional ones.*



**TRAVERSINO PER MANUBRIO  
CROSSBEAM FOR HANDLEBAR**  
.....  
COD. 605985M

Traversino per manubrio in alluminio verniciato di nero, per trasformare il manubrio di serie della tua V7 in uno da vero fuoristrada.

*Crossbeam for black painted aluminium handlebar to transform the factory handlebar of your V7 into a true motorcycle handlebar.*



**SCARICO ARROW  
ARROW EXHAUST**  
.....  
COD. 2S000311 ABS  
COD. 2S000313 NO ABS  
MONOCORPO/SINGLE THROTTLE BODY  
COD. 2S000666 NO ABS  
DOPPIO CORPO/DOUBLE THROTTLE BODY

Scarico 2 in 1 con silenziatore, moderno nella tecnologia ma classico nel look. Per montare lo scarico è necessaria una staffa: se con parafango in alluminio 2S000325 oppure con parafango in plastica 2S000324.

*2 in 1 exhaust system with silencer made in modern technology but with a classic look. With aluminium mudguard you need 2S000325, with plastic mudguard you need 2S000324.*



**STAFFA PER SCARICO  
HIGH EXHAUST SUPPORT BRACKET**  
.....  
COD. 2S000325  
PARAFANGO ALLUMINIO  
ALUMINIUM MUDGUARD  
COD. 2S000324  
PARAFANGO PLASTICA/PLASTIC MUDGUARD

Staffa per il montaggio dello scarico alto.  
*Bracket for the mounting of the high exhaust.*





**PUNTALE PEDALE  
IN ALLUMINIO LAVORATO  
ALUMINIUM FINISHED FOOTPEG  
PUSH ROD**

.....  
COD. 2S000323

Nel caso di utilizzo dello scarico alto 2S000311 e 2S000313. Il codice corrisponde ad un puntale pedana: è necessario ordinare due pezzi.

*In case of use of high exhaust 2S000311 and 2S000313. The code corresponds to one footpeg push rod: two pieces must be ordered.*



**COPPIA PEDANE PILOTA  
WIDER FOOTPEGS PAIR**

.....  
COD. 2S000451

Coppia di pedane maggiorate, finite con superficie zigrinata, per consentire il miglior appoggio del piede.

*Pair of wider footpegs, finished with knurled surface in case of use of exhaust 2S000311 and 2S000313 to get a better support of the feet.*



**BORSA LATERALE  
CUOIO NATURALE  
NATURAL LEATHER SIDE BAG**

.....  
COD. 2S000264 SINISTRA/LEFT  
COD. 2S000295 DESTRA/RIGHT

Borsa di cuoio naturale finito con una concia vegetale da agganciare sui lati della parte posteriore della tua V7. Si fissa ai telaietti specifici 2S000280 (sinistra) e 2S000294 (destra), da acquistare separatamente.

*Natural leather bag finished with a vegetable tan to be mounted on the rear sides of your V7. It is fixed to the specific subframes 2S000280 (left) and 2S000294 (right), to be purchased separately.*



**BORSA LATERALE CUOIO NERO  
BLACK LEATHER SIDE BAG**

.....  
COD. 2S000296 SINISTRA/LEFT  
COD. 2S000297 DESTRA/RIGHT

Borsa di cuoio naturale finito con una concia vegetale da agganciare sui lati della parte posteriore della tua V7. Si fissa ai telaietti specifici 2S000280 (sinistra) e 2S000294 (destra), da acquistare separatamente.

*Natural leather bag finished with a vegetable tan to be mounted on the rear sides of your V7. It is fixed to the specific subframes 2S000280 (left) and 2S000294 (right), to be purchased separately.*



**SELLA CON IMBOTTITURE  
PADDED SADDLE**

.....  
COD. 2S000262

Sella per la tua V7 con seduta un po' più ridotta rispetto a quella di serie montata sulla moto. Perfetta per guidare in una posizione più aerodinamica e anche per permetterti, quando serve, di portare una persona. Logo Moto Guzzi ricamato.

*Smaller saddle for your V7 than the one that is factory mounted on the bike. Perfect for riding in a more aerodynamic position as well as for allowing you to ride two-up when necessary. Moto Guzzi Logo embroidered.*



**AMMORTIZZATORI  
PERFORMANCE ROSSO  
RED PERFORMANCE  
SHOCK ABSORBERS**

.....  
COD. 606091M  
COD. 2S000257 MAGGIORATI/EXTENDED LENGHT

Con serbatoio gas separato, regolabili in estensione, compressione e precarico, migliorano comfort e guidabilità grazie alle eccezionali caratteristiche tecniche che li contraddistinguono. Molla rossa.

*With separate gas tank, adjustable in size, compression and preload, improved comfort and handling thanks to exceptional technical features that distinguish them.*

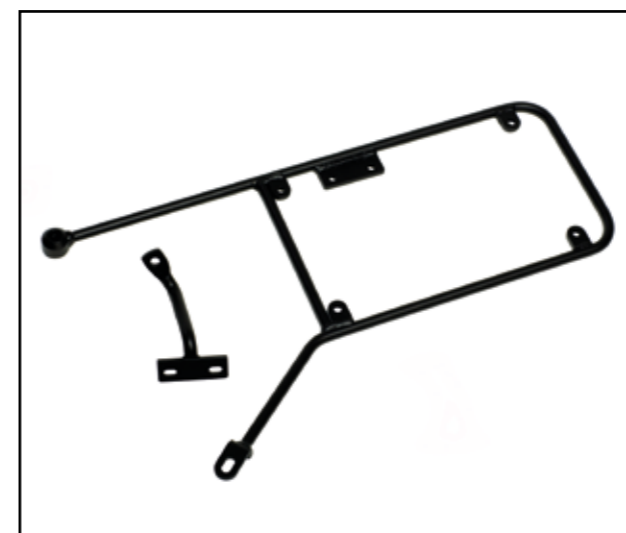

**TELAIETTO PER BORSA LATERALE  
SIDE BAG SUBFRAME**

.....  
COD. 2S000280 SINISTRA/LEFT  
COD. 2S000294 DESTRA/RIGHT

Supporto di metallo, necessario per fissare la borsa laterale sinistra in cuoio naturale 2S000264 o in cuoio nero 2S000296.

*Metal support, necessary to secure the left side bag in natural leather 2S000264 or black leather 2S000296.*



**BORSA PORTA ATTREZZI NERA  
BLACK LEATHER TOOLS BAG**

.....  
COD. 605989M

Borsa portatutto in cuoio nero finito con una concia vegetale, agganciabile sul portapacchi o sul serbatoio (con l'apposita fascia dello stesso colore). La borsa è resistente all'acqua e non ha bisogno di cure particolari.

*A carry-all bag in black leather finished with a vegetable tan, can be attached to the luggage rack or fuel tank (with the appropriate band of the same colour). The bag is water resistant and does not need special care.*





**BORSA PORTA ATTREZZI MARRONE**  
**BROWN LEATHER TOOLS BAG**

.....  
COD. 605991M

Borsa portatutto in cuoio naturale finito con una concia vegetale, agganciabile sul portapacchi o sul serbatoio (con l'apposita fascia dello stesso colore). La borsa è resistente all'acqua e non ha bisogno di cure particolari.

*A carry-all bag in brown leather finished with a vegetable tan, can be attached to the luggage rack or fuel tank (with the appropriate band of the same colour). The bag is water resistant and does not need special care.*



**SUPPORTO TARGA**  
**LICENCE PLATE HOLDER**

.....  
COD. 2S000282  
COD. 2S000500 USA

Sostegno ad arco per la targa, da utilizzare con i parafanghi in alluminio gruppo ottico di serie.

*Bracket support for the plate, to be used with aluminium mudguards and the factory taillight assembly.*



**PORTAPACCHI PICCOLO NERO**  
**SMALL LUGGAGE RACK**

.....  
COD. 2S000256

Un portapacchi di dimensioni ridotte in metallo verniciato nero. È pensato per agganciarci la borsa porta attrezzi, ma è perfetto anche per il tuo prossimo viaggio.

*A small luggage rack in black painted metal. It is designed to attach the tool bag (605989M or 605991M), but is also perfect for your next trip.*



**NUMERI ADESIVI**  
**ADHESIVE NUMBERS**

.....  
COD. 605983M

Il numero di Omobono "The Black Devil" Tenni, uno dei più grandi piloti della storia. Da mettere sulle tabelle frontali e laterali per viaggiare con un eroe della Moto Guzzi.

*Omobono "The Black Devil" Tenni's number, one of the greatest riders in history. To be applied to the front and side number plates to travel with a Moto Guzzi hero.*



**SUPPORTI FRECCHE**  
**TURN INDICATOR BRACKETS**

.....  
COD. 2S000266

Supporti in alluminio per montare le frecce posteriori nel caso di adozione del supporto porta targa 2S000282 per parafanghi in alluminio. Avvicinando gli indicatori di direzione alla sella, lasciano il posteriore più libero di esprimere tutto lo stile.

*Aluminium mounting brackets for the factory rear turn indicators if a license plate bracket for 2S000282 aluminium mudguards is used. These bring the turn indicators closer to the saddle, leaving the rear more free to express all the style.*



**SOFFIETTO FORCELLA**  
**RUBBER FORK STANCHION**  
**DUST BOOTS**

.....  
COD. 606123M

Soffietto in gomma per proteggere gli steli della tua V7 dalla polvere, dai residui sulla strada e da qualsiasi cosa incontrerai nelle tue avventure. Il codice corrisponde ad una estensione pedana: è necessario ordinare due pezzi.

*Rubber boot to protect the fork stanchions on your V7 from dust, road residue and anything else you may encounter on your adventures. The code corresponds to one dust boot: two pieces must be ordered.*



**PNEUMATICI OFFROAD**  
**OFFROAD TYRES**

.....  
COD. 606018M

Pneumatici omologati per la V7. Il battistrada tassellato consente un'ottima tenuta su qualsiasi percorso o sentiero.

*Approved offroad tyres for V7. The knobby tread provides excellent grip on any route. Or path.*



  
**MOTO GUZZI®**

**ACCESSORI  
ACCESSORIES**



**STYLE**



**THE POWER OF HISTORY**





**KIT OLIVE GREEN  
OLIVE GREEN KIT**

.....  
COD. 606329M  
COD. 606221M USA

Kit completo composto da serbatoio, e parafanghi nel verde dell'Alce, storico modello Moto Guzzi. Trasforma completamente l'aspetto della V7.

*Complete kit that includes the fuel tank and mudguards painted in Alce green, the historic Moto Guzzi model. It will completely transform the look of your V7.*



**KIT CAMOUFLAGE  
CAMOUFLAGE KIT**

.....  
COD. 605990M

Kit completo composto da serbatoio, parafanghi e fianchetti laterali graficati in camouflage, per trasformare completamente l'aspetto della V7.

*Complete kit that includes the fuel tank, mudguards and side panels in camouflage graphics to completely transform the look of your V7.*



**TRAVERSINO PER MANUBRIO  
CROSSBEAM FOR HANDLEBAR**

.....  
COD. 605985M

Traversino per manubrio in alluminio verniciato di nero, per trasformare il manubrio di serie della tua V7 in uno da vera moto speciale.

*Crossbeam for black painted aluminium handlebar to transform the factory handlebar of your V7 into a true motorcycle handlebar.*



**PEDANE OFF ROAD PILOTA  
OFF ROAD FOOTPEG KIT**

.....  
COD. 25000258

Kit di pedane pensate appositamente per l'utilizzo offroad. Consentono di non perdere l'appoggio anche nelle condizioni fuoristrada.

*Footpegs kit for your V7 designed specifically for offroad use. They will help you not to lose solid footing even in off road conditions.*



**SCARICO ARROW  
ARROW EXHAUST**

.....  
COD. 25000311 ABS  
COD. 25000313 NO ABS  
MONOCORPO/SINGLE THROTTLE BODY  
COD. 25000666 NO ABS  
DOPPIO CORPO/DOUBLE THROTTLE BODY

Scarico 2 in 1 con silenziatore, moderno nella tecnologia ma classico nel look. Per montare lo scarico è necessaria una staffa: se con parafango in alluminio 25000325 oppure con parafango in plastica 25000324.

*2 in 1 exhaust system with silencer made in modern technology but with a classic look. With aluminium mudguard you need 25000325, with plastic mudguard you need 25000324.*



**STAFFA PER SCARICO  
PARAFANGO IN PLASTICA  
HIGH EXHAUST SUPPORT BRACKET  
PLASTIC MUDGUARD**

.....  
COD. 25000324

Staffa per il montaggio dello scarico alto.  
*Bracket for the mounting of the high exhaust.*





**ESTENSIONE PEDANA  
IN ALLUMINIO LAVORATO  
ALUMINIUM FOOTPEG EXTENSION**  
.....

**COD. 2S000320**

Da applicare alle pedane offroad 2S000258 nel caso di utilizzo dello scarico 2S000311 e 2S000313. Il codice corrisponde ad una estensione pedana: è necessario ordinare due pezzi.

*To be applied to the offroad footpeg 2S000258 in case of use of exhaust 2S000311 and 2S000313. The code corresponds to one footpeg extension: two pieces must be ordered.*



**PUNTALE PEDALE  
IN ALLUMINIO LAVORATO  
ALUMINIUM FINISHED  
FOOTPEG PUSH ROD**  
.....

**COD. 2S000323**

Nel caso di utilizzo dello scarico alto 2S000311 e 2S000313. Il codice corrisponde ad un puntale pedana: è necessario ordinare due pezzi.

*In case of use of high exhaust 2S000311 and 2S000313. The code corresponds to one footpeg push rod: two pieces must be ordered.*



**AMMORTIZZATORI  
PERFORMANCE NERI  
BLACK PERFORMANCE  
SHOCK ABSORBERS**  
.....

**COD. 897773**

**COD. 2S000281 MAGGIORATI/EXTENDED LENGHT**

Con serbatoio gas separato, regolabili in estensione, compressione e precarico, migliorano comfort e guidabilità grazie alle eccezionali caratteristiche tecniche che li contraddistinguono. Molla nera.

*With separate gas tank, adjustable in size, compression and preload, improved comfort and handling thanks to exceptional technical features that distinguish them.*



**BORSA LATERALE CUOIO NATURALE  
NATURAL LEATHER SIDE BAG**  
.....

**COD. 2S000264 SINISTRA/LEFT**

**COD. 2S000295 DESTRA/RIGHT**

Borsa di cuoio naturale finito con una concia vegetale da agganciare sui lati della parte posteriore della tua V7. Si fissa ai telaietti specifici 2S000280 (sinistra) e 2S000294 (destra), da acquistare separatamente.

*Natural leather bag finished with a vegetable tan to be mounted on the rear sides of your V7. It is fixed to the specific subframes 2S000280 (left) and 2S000294 (right), to be purchased separately.*



**COPPIA PEDANE PILOTA  
WIDER FOOTPEGS PAIR**  
.....

**COD. 2S000451**

Coppia di pedane maggiorate, finite con superficie zigrinata, per consentire il miglior appoggio del piede.

*Pair of wider footpegs, finished with knurled surface in case of use of exhaust 2S000311 and 2S000313 to get a better support of the feet.*



**SELLA TRAPUNTATA  
PADDED SADDLE**  
.....

**COD. 2S000262**

Sella trapuntata per la tua V7 con seduta un po' più ridotta rispetto a quella di serie montata sulla moto. Perfetta per guidare in una posizione più aerodinamica e anche per permetterti, quando serve, di portare una persona. Logo Moto Guzzi ricamato.

*Smaller saddle for your V7 than the one that is factory mounted on the bike. Perfect for riding in a more aerodynamic position as well as for allowing you to ride two-up when necessary. Moto Guzzi Logo embroidered.*



**BORSA LATERALE CUOIO NERO  
BLACK LEATHER SIDE BAG**  
.....

**COD. 2S000296 SINISTRA/LEFT**

**COD. 2S000297 DESTRA/RIGHT**

Borsa di cuoio naturale finito con una concia vegetale da agganciare sui lati della parte posteriore della tua V7. Si fissa ai telaietti specifici 2S000280 (sinistra) e 2S000294 (destra), da acquistare separatamente.

*Natural leather bag finished with a vegetable tan to be mounted on the rear sides of your V7. It is fixed to the specific subframes 2S000280 (left) and 2S000294 (right), to be purchased separately.*

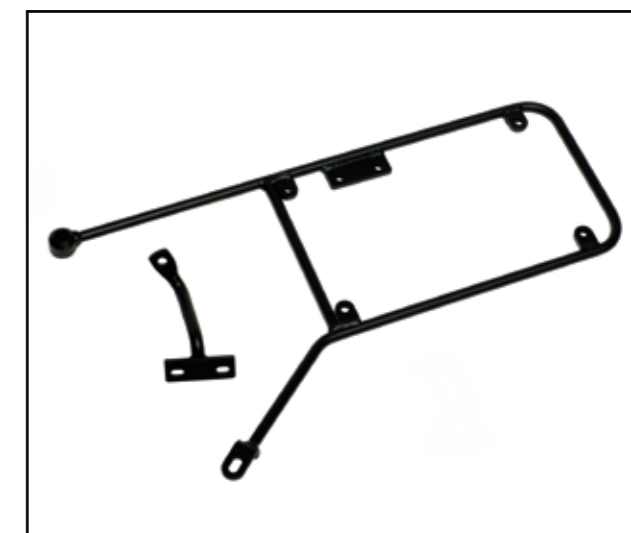

**TELAIETTO PER BORSA LATERALE  
SIDE BAG SUBFRAME**  
.....

**COD. 2S000280 SINISTRA/LEFT**

**COD. 2S000294 DESTRA/RIGHT**

Supporto di metallo, necessario per fissare la borsa laterale sinistra in cuoio naturale 2S000264 o in cuoio nera 2S000296.

*Metal support, necessary to secure the left side bag in natural leather 2S000264 or black leather 2S000296.*





**BORSA PORTA ATTREZZI NERA  
BLACK LEATHER TOOLS BAG**

.....  
COD. 605989M

Borsa portatutto in cuoio nero finito con una concia vegetale, agganciabile sul portapacchi o sul serbatoio (con l'apposita fascia dello stesso colore). La borsa è resistente all'acqua e non ha bisogno di cure particolari.

*A carry-all bag in black leather finished with a vegetable tan, can be attached to the luggage rack or fuel tank (with the appropriate band of the same colour).*

*The bag is water resistant and does not need special care.*



**BORSA PORTA ATTREZZI MARRONE  
BROWN LEATHER TOOLS BAG**

.....  
COD. 605991M

Borsa portatutto in cuoio naturale finito con una concia vegetale, agganciabile sul portapacchi o sul serbatoio (con l'apposita fascia dello stesso colore). La borsa è resistente all'acqua e non ha bisogno di cure particolari.

*A carry-all bag in brown leather finished with a vegetable tan, can be attached to the luggage rack or fuel tank (with the appropriate band of the same colour).*

*The bag is water resistant and does not need special care.*



**PORTAPACCHI NERO  
BLACK PAINTED LUGGAGE RACK**

.....  
COD. 2S000259

Un portapacchi lungo, per aumentare la capacità di carico della V7. È verniciato di nero per abbinarsi perfettamente con la livrea della moto.

*A long luggage rack to increase the cargo capacity of your V7. It's painted black so it matches the bike's livery perfectly.*



**PNEUMATICI OFFROAD  
OFFROAD TYRES**

.....  
COD. 606018M

Pneumatici omologati per la V7. Il battistrada tassellato consente un'ottima tenuta su qualsiasi percorso o sentiero.

*Approved offroad tyres for V7. The knobby tread provides excellent grip on any route. Or path.*







ELDORADO





**PARABREZZA MEDIO  
SUPPORTI RIBASSATI  
MEDIUM WINDSHIELD  
LOWER BRACKETS**

.....  
COD. 2S000544

Parabrezza di misura media con la lastra in Lexan antiurto e antigraffio. Omologato secondo le normative DOT. Si monta facilmente grazie ai supporti ribassati da acquistare separatamente. H44 x L52 cm.

*Medium sized windshield with shockproof and scratch resistant Lexan sheet. Approved according to the DOT standards. It is easy to mount due to its lowered brackets, to be purchased separately. H44xL52 cm.*



**KIT SUPPORTI PARABREZZA  
RIBASSATI  
WINDSHIELD LOWER BRACKETS KIT**

.....  
COD. 2S000542

Robusto kit di fissaggio, a misura ridotta, dotato di supporti specifici per il montaggio del parabrezza.

*Small sized solid fastening kit, equipped with specific brackets for mounting the windshield.*



**PARABREZZA-SUPPORTI STANDARD  
WINDSHIELD-STANDARD BRACKETS**

.....  
COD. 605854M

Parabrezza con la lastra in Lexan antiurto e antigraffio, un materiale pregiatissimo che assicura la massima durata nel tempo mantenendo inalterate le sue caratteristiche di trasparenza e lucentezza. Il Lexan è omologato secondo le ferree normative DOT americane. H57 x L58 cm.

*Windshield made in shockproof and scratch resistant Lexan sheet, a precious material that ensures maximum durability, maintaining its transparency and gloss characteristics unaltered over time. Lexan is approved according to the strict American DOT regulations. H57 x L58 cm.*



**DEFLETTORI ARIA PARABREZZA  
WINDSHIELD AIR FLAPS**

.....  
COD. B064235

Appendici da applicare nella zona sottostante al parabrezza per aumentare la protezione ed il comfort di guida offerti al pilota.

*Spoilers to be applied under the windshield to increase rider's protection and driving comfort.*



**PARABREZZA SPORT  
SUPPORTI RIBASSATI  
SPORT WINDSHIELD  
LOWER BRACKETS**

.....  
COD. 2S000548

Parabrezza di misura particolarmente ridotta, con la lastra in Lexan antiurto e antigraffio, che mantiene inalterate le caratteristiche di trasparenza e lucentezza. Omologato secondo le normative DOT. Si monta facilmente grazie ai supporti ribassati da acquistare separatamente. H34 x L41 cm.

*Specially reduced windshield with shockproof and scratch resistant Lexan sheet, maintaining the transparency and gloss characteristics unaltered over time. Approved according to the DOT standards. It is easy to mount due to its lowered brackets, to be purchased separately. H34 x L41 cm.*



**PARABREZZA MEDIO  
SUPPORTI STANDARD  
MEDIUM WINDSCREEN  
STANDARD BRACKETS**

.....  
COD. 2S000546

Parabrezza di misura media con la lastra in Lexan antiurto e antigraffio, che mantiene nel tempo inalterate le caratteristiche di trasparenza e lucentezza. Omologato secondo le normative DOT. Si monta facilmente grazie ai supporti Standard da acquistare separatamente. H44 X L52 cm.

*Medium sized windshield with shockproof and scratch resistant Lexan sheet, maintaining the transparency and gloss characteristics unaltered over time. Approved according to the DOT standards. Can be easily mounted due to the standard brackets, to be purchased separately. H44 X L52 cm.*



**PARABREZZA GRANDE  
SUPPORTI STANDARD  
WIDE WINDSCREEN  
STANDARD BRACKETS**

.....  
COD. 2S000547

Parabrezza di misura grande con la lastra in Lexan antiurto e antigraffio, che mantiene nel tempo inalterate le caratteristiche di trasparenza e lucentezza. Omologato secondo le normative DOT. Si monta facilmente grazie ai supporti standard da acquistare separatamente. H70 x L59 cm.

*Large sized windshield made in shockproof and scratch resistant Lexan sheet, maintaining the transparency and gloss characteristics unaltered over time. Approved according to the DOT standards. Can be easily mounted due to the standard brackets, to be purchased separately. H70 x L59 cm.*



**KIT SUPPORTI PARABREZZA  
STANDARD  
WINDSCREEN STANDARD  
BRACKETS KIT**

.....  
COD. 605853M

Robusto kit di fissaggio, a misura standard, dotato di supporti specifici per il montaggio del parabrezza. Necessita delle minuterie 606255M.

*Standard size solid fastening kit, equipped with specific brackets for windshield mounting. Requires 606255M small metallic parts.*





**MINUTERIE PER SUPPORTI  
PARABREZZA STANDARD  
WINDSCREEN STANDARD BRACKETS  
SMALL METALLIC PARTS**

.....  
COD. 606255M

Minuterie necessarie per il montaggio del kit supporti parabrezza standard 605853M.

*Small metallic parts required to mount the standard windshield brackets kit 605853M.*



**SPECCHI "JOURNEY" IN ALLUMINIO  
ALUMINIUM MIRRORS KIT "JOURNEY"**

.....  
COD. 2S000333

Realizzati in alluminio ricavato dal pieno con il loro design semplice ma di tendenza contribuiscono a donare eleganza alla moto. La coppa specchio racchiude il massimo della tecnologia realizzativa che si esprime in alcune lavorazioni speciali realizzate sui tre assi. Sono omologati per tutti i Paesi.

*Made from billet aluminium they contribute with their simple, but trendy design to add elegance to the motorcycle.*

*The mirror cover contains the maximum state of the technology expressed in some special works performed on the three axes. They are approved for all countries.*



**TERMINALI MANOPOLE "CORSA"  
IN ALLUMINIO  
ALUMINIUM GRIPS ENDPIPES  
"CORSA"**

.....  
COD. 2S000339

I terminali manopole "Corsa", realizzati in alluminio ricavato dal pieno, si accoppiano alle manopole "Journey", realizzando un perfetto completamento stilistico ed estetico.

*The "Corsa" handlebar ends, made from billet aluminium, match the journey grips, achieving a perfect stylistic and aesthetic finishing.*



**TERMINALI MANOPOLE "CLASSIC"  
GRIPS ENDPIPES "CLASSIC"**

.....  
COD. 2S000341

I terminali manopole "Classic", realizzati in alluminio ricavato dal pieno, si accoppiano alle manopole standard, realizzando un perfetto completamento stilistico ed estetico.

*The "Classic" handlebar ends, made from billet aluminium, match the standard grips, achieving a perfect stylistic and aesthetic finishing.*



**MANOPOLE "JOURNEY" IN ALLUMINIO  
ALUMINIUM HANDGRIP KIT "JOURNEY"**

.....  
COD. 2S000335

Realizzate in alluminio ricavate dal pieno, impreziosiscono il manubrio della moto donandole un look personalizzato ed elegante, sono predisposte per il montaggio dei terminali "Round".

*Made from billet aluminium, they embellish the handlebar of the motorcycle, giving a personal and elegant look. Compatible with "round" ends.*



**TERMINALI MANOPOLE "ROUND"  
IN ALLUMINIO  
ALUMINIUM GRIPS ENDPIPES "ROUND"**

.....  
COD. 2S000337

I terminali manopole "Round", realizzati in alluminio ricavato dal pieno, si accoppiano alle manopole "Journey", realizzando un perfetto completamento stilistico ed estetico.

*The "Round" handlebar ends, made from billet aluminium, match the "Journey" handlebars, achieving a perfect stylistic and aesthetic finishing.*



**LEVA FRIZIONE "SHOW OFF"  
IN ALLUMINIO  
ALUMINIUM CLUTCH  
LEVER "SHOW OFF"**

.....  
COD. 2S000342

Realizzata in alluminio ricavata dal pieno, grazie alla sua consistenza ed alle sue regolazioni eleva il comfort di guida impreziosendo il look della moto.

*Made from billet aluminium, due to its consistency and adjustments, it increases the driving comfort embellishing the look of the motorcycle.*



**LEVA FRENO ANTERIORE  
"SHOW OFF" IN ALLUMINIO  
ALUMINIUM FRONT BRAKE  
LEVER "SHOW OFF"**

.....  
COD. 2S000343

Realizzata in alluminio ricavata dal pieno, grazie alla sua consistenza ed alle sue regolazioni eleva il comfort di guida impreziosendo il look della moto.

*Made from billet aluminium, due to its consistency and adjustments, it increases the driving comfort embellishing the look of the motorcycle.*





**KIT COPERCHIO POMPA  
FRENO E FRIZIONE  
BRAKE AND CLUTCH  
PUMP COVER KIT**

COD. B064259

Speciali coperchi delle pompe freno e frizione realizzati in alluminio ricavati dal pieno con finitura antigraffio lucida.

*Special covers for brake and clutch pumps made from billet aluminium with glossy scratch resistant finishing.*



**MANOPOLE RISCALDATE  
HEATED HANDGRIPS**

COD. B064270

Per chi ama viaggiare a lungo in tutte le stagioni, facilmente installabili grazie alla predisposizione presente su tutte le California. Contribuiscono al comfort di guida, evitando che le mani possano indolenzirsi a causa del freddo.

*For those who love travelling in all seasons, easily mountable due to the arrangement on all California. They contribute to the driving comfort, preventing hand stiffening because of the cold.*



**PEDALINO FRENO POSTERIORE  
"JOURNEY" IN ALLUMINIO  
ALUMINIUM FOOTSWITCH  
BRAKE "JOURNEY"**

COD. 2S000351

Cover per pedalino realizzata in alluminio ricavato dal pieno, con lavorazione per garantire il massimo grip. Unitamente alla cover leva freno posteriore impreziosisce notevolmente il look del comando freno posteriore.

*Pedal cover made of billet aluminium, developed to guarantee the maximum grip. Together with the rear brake lever cover, embellishes significantly the look of the rear brake control.*



**KIT LEVA CAMBIO "JOURNEY"  
IN ALLUMINIO  
ALUMINIUM GEAR LEVER  
KIT "JOURNEY"**

COD. 2S000352

Cover realizzata in alluminio ricavato dal pieno, impreziosisce il comando cambio.

*The cover made of billet aluminium embellishes the gear shift lever.*



**KIT SUPPORTO GPS  
GPS BRACKET**

COD. B064243

Supporto realizzato in acciaio inox lucido con predisposizione per il montaggio del navigatore satellitare.

*Bracket made of glossy stainless steel with arrangement for mounting the satellite navigator.*



**KIT LEVA FRENO POSTERIORE  
"JOURNEY" IN ALLUMINIO  
ALUMINIUM REAR BRAKE LEVER  
"JOURNEY"**

COD. 2S000350

Cover realizzata in alluminio ricavata dal pieno, unitamente alla cover del pedalino del freno impreziosisce il comando freno posteriore.

*Cover made of billet aluminium, together with the brake pedal cover embellishes the rear brake control.*



**COVER SERBATOIO OLIO FRENO  
POSTERIORE  
BRAKE OIL TANK COVER**

COD. B064288

Realizzato in alluminio ricavato dal pieno, con una finitura lucida, personalizza il look del veicolo. Ricopre completamente il corpo del serbatoio olio freno lasciando inalterate le funzionalità. È di facile installazione.

*Made from billet aluminium, with a polished finish, it customizes the look of the vehicle. Covers completely the body of the brake oil tank, without altering the functions. Easy to mount.*



**CRESTA PARAFANGO ANTERIORE  
FRONT FENDER PEAK**

COD. 2S000353

Realizzata in acciaio inox, tagliata ed incisa a laser, lucidata a mano, il suo montaggio sul parafango è garantito dalle speciali colonnine in acciaio inox. Completa il look classico della moto.

*Made of stainless steel, laser-cut and engraved, manually polished, its mounting on the mudguard is guaranteed by two special stainless steel columns. Finishes the classical look of the motorcycle.*





**COPRI STELI FORCELLA  
FORK SLEEVE COVERS**

.....  
COD. B064252

I copri steli forcella con finitura cromata si abbinano agli altri elementi in alluminio, già presenti sul veicolo, per esaltare le zone laterali.

*The fork sleeve covers with chrome finishing match the other aluminium elements, already mounted on the vehicle, to enhance the side areas.*



**COVER TAPPI FORCELLA  
IN ALLUMINIO  
ALUMINIUM FORK TOP CAPS COVER**

.....  
COD. 2S000402

Realizzati in alluminio ricavato dal pieno, facilmente installabili, sono stabilmente fissati alle viti che chiudono gli steli forcella mediante un piccolo grano in acciaio.

*Made of billet aluminium, easy to mount, they are solidly fastened to the screws that fix the fork stems with a small steel peg.*



**GUANCIALI SERBATOIO CROMATI  
CHROMED TANK COVERS**

.....  
COD. B064244

Le cover laterali del serbatoio cromate personalizzano lo stile della moto rendendola una vera «fuoriserie».

*The side tank covers, made of steel with chromed finish, customize the style of the motorcycle, making it a "custom-built" vehicle.*



**COVER TESTE CON LAVORAZIONE  
GRIGIO  
CYLINDERS COVERS KIT - GREY**

.....  
COD. 2S000364

Eleganti cover teste cilindro verniciate, con speciali lavorazioni eseguite in fresatura, rappresentano uno speciale elemento di personalizzazione del veicolo.

*Elegant painted cylinder heads covers, with special processes performed in milling, they represent a special element of customization to the vehicle.*



**MANUBRIO TOURING CROMATO NERO  
BLACK CHROMED HANDLEBAR TOURING**

.....  
COD. B064246

Per una personalizzazione esclusiva della propria moto, sviluppato dai collaudatori Moto Guzzi, il manubrio cromato nero consente di mantenere la posizione di guida ottimale per il controllo della moto. Da oliare periodicamente per proteggere e mantenere lucida la cromatura.

*For an exclusive customization of your motorcycle, developed by the Moto Guzzi testers, the black chrome handlebar keeps the optimum driving position for the control of the motorcycle. To be oiled regularly to protect and maintain the gloss of the chromium coating.*



**KIT COVER DISCHI FRENO ANTERIORE  
FRONT BRAKE COVER KIT**

.....  
COD. 2S000467

Realizzati in acciaio inox tagliati a laser e lucidati a specchio, grazie alla loro lavorazione particolarmente precisa sono facilmente installabili sui dischi della ruota anteriore con bussole di fissaggio realizzate in alluminio ricavate dal pieno. Donano al veicolo un look cruiser.

*Made in laser-cut and high-gloss polished stainless steel, thanks to their particular accurate machining, they can be easily mounted on the front wheel discs with fastening bushings made from billet aluminium. They provide the vehicle with a cruiser look.*



**COVER TESTE CON LAVORAZIONE  
ROSSO  
CYLINDERS COVERS KIT - RED**

.....  
COD. 2S000600

Eleganti cover teste cilindro verniciate, con speciali lavorazioni eseguite in fresatura, rappresentano uno speciale elemento di personalizzazione del veicolo.

*Elegant painted cylinder heads covers, with special processes performed in milling, they represent a special element of customization to the vehicle.*



**SET BUSSOLE TESTATA IN ALLUMINIO  
ALUMINIUM HEAD BUSHINGS SET**

.....  
COD. 2S000348

Set di quattro distanziali in alluminio ricavato dal pieno, da montare in sostituzione delle viti che fissano le cover delle teste cilindro. Le viti a corredo sono in acciaio inox lucidato.

*Set of four aesthetic spacers made from billet aluminium, to be mounted in place of the screws supplied with the kit that hold the cover of the cylinder head. The screws supplied with the vehicle are made of polished stainless steel.*





**KIT PROTEZIONE TESTE  
CYLINDER COVERS PROTECTION KIT**

.....  
COD. B064247

Speciali protezioni laterali cilindri realizzate in alluminio ricavato dal pieno finite con la lucidatura a specchio. Si integrano perfettamente con lo stile ed il design della moto. Complete di supporti in acciaio inox lucidati a specchio.

*Special cylinder side shields made from billet aluminium, finished with high-gloss polishing. They perfectly match with style and design of the motorcycle. Provided with high-gloss polished stainless steel brackets.*



**KIT PARACALORE CILINDRI  
THERMAL PROTECTION SET**

.....  
COD. 2S000032

Ogni paracalore è realizzato in acciaio inox lucidato a specchio, con inserti in abs che migliorano il design ed attenuano il contatto delle ginocchia con il motore. Proteggono dal calore generato dal cilindro, per una guida più sicura e confortevole.

*Each heat shield is made from high-gloss polished stainless steel, with abs inserts improving design and reducing the contact of the knees with the engine. They protect from the heat generated by the cylinder, for a more secure and comfortable driving.*



**COVER FORI BASAMENTO MOTORE  
CRANKCASE ENGINE HOLES COVER**

.....  
COD. 2S000403

Realizzati in alluminio tagliato al laser lucidati, consentono di coprire i fori di lavorazione di basamento del motore. La scritta "1400" realizzata al laser indica chiaramente la cilindrata del motore, evidenziando l'importanza del veicolo.

*Made of polished laser-cut aluminium, they cover the machining holes on the engine crankcase. The laser made "1400" mark, gives a clear message regarding the size of the engine, underlining the exclusivity of the vehicle.*



**COVER CLACSON IN ALLUMINIO  
ALUMINIUM HORNS COVER**

.....  
COD. 2S000466

Cover in alluminio ricavato dal pieno, si applica ai clacson per dare un look sportivo alla moto.

*The billet aluminium cover is applied to the horns giving the motorcycle a sportive look.*



**PARAURTI MOTORE ANTERIORE  
ENGINE FRONT BUMPER**

.....  
COD. B063588

Disegnato in tubo cromato dal Centro Stile Moto Guzzi, segue le linee della moto. Offre una protezione specifica al motore ed alle gambe del pilota.

*Designed by the Moto Guzzi Style Centre, this bumper in chromed tube follows the lines of the motorcycle. It offers specific protection to the engine and driver's legs.*



**CORNICE RADIATORE OLIO  
OIL RADIATOR FRAME SET**

.....  
COD. 2S000349

Realizzato in alluminio lucidato tagliato al laser, completo di rete protettiva, si applica al radiatore conferendo un look classico e raffinato.

*Made in polished laser-cut aluminium, completed with protective grid, it is applied to the radiator giving a classic and stylish look.*



**PEDANE PILOTA  
PILOT FOOTRESTS**

.....  
COD. B064249

Pedane pilota reclinabili realizzate in alluminio ricavato dal pieno lucidate a specchio, mantengono la stessa ergonomia di guida di quelle di serie ma offrono un design alleggerito e personalizzato in linea con lo stile della moto.

*Reclining rider footpegs made of high-gloss polished billet aluminium, they maintain the same driving ergonomics like the standard ones, but offer a light-weight and customized design in line with the style of the motorcycle.*



**PEDANE PASSEGGERO RIPIEGABILI  
PASSENGER FOOTRESTS**

.....  
COD. B064248

Realizzate in alluminio ricavato dal pieno lucidate a specchio. Mantengono lo stesso design delle pedane pilota. Regolabili orizzontalmente in 4 posizioni attraverso un meccanismo a molla che facilita il loro posizionamento ottimale.

*Made of high-gloss polished billet aluminium. Maintain the same design of the rider footpegs. Horizontally adjustable in 4 positions thanks to a spring mechanism that makes the ideal positioning very easy.*





**KIT LUCI SUPPLEMENTARI  
FOG LIGHTS KIT**

.....  
COD. B064251

I fari supplementari offrono una migliore visibilità durante la guida notturna e si integrano perfettamente con il look del veicolo grazie alle finiture cromate. I due fari vengono installati sotto gli indicatori di direzione tramite staffe appositamente studiate per non compromettere la guidabilità del mezzo.

*The additional headlamps offer better visibility during night driving, completing perfectly the look of the vehicle thanks to their chromed finishing. The two headlamps are mounted under the turn indicators with clamps specifically designed to avoid compromising the driving of the vehicle.*



**ROSETTE FORCELLONE  
SWINGARM WASHERS**

.....  
COD. B064272

Rosette speciali realizzate in alluminio ricavate dal pieno per personalizzare lo stile della tua California.

*Special washers made of billet aluminium to personalize the style of your California.*



**FASCIA PER BORSA SERBATOIO  
IN PELLE  
LEATHER TANK COVER**

.....  
COD. 2S000524

Cover realizzata in pelle che segue perfettamente il profilo del serbatoio e permette di montare la borsa dedicata.

*Leather tank cover, perfectly matching with tank profile and allows to mount the dedicated tank bag.*



**COPPIA BORSE LATERALI IN PELLE  
BLACK LEATHER SIDE BAGS KIT**

.....  
COD. 2S000526

Coppia di borse laterali in pelle nere con taglio classico, ciascuna di 23 lt, sono fissate ai telaietti con una serratura che ne impedisce la rimozione. Contengono una tracolla regolabile per il loro trasporto. Per il montaggio sono necessari i supporti laterali (cod. 2S000538).

*Set of two Classic-cut black leather bags, 23 litres each, mounted on specific subframes equipped with a lock to prevent removal. They contain an adjustable shoulder strap for transport. Side brackets are needed for mounting (cod. 2S000538).*



**BORSA MANUBRIO  
HANDLEBAR BAG**

.....  
COD. 2S000034

Elegante e funzionale borsa-manubrio realizzata in cordura e pelle naturale che incornicia il marchio Moto Guzzi, utile per contenere piccoli oggetti. La sua funzionalità è garantita dalla facile installazione e rimozione dal manubrio del veicolo.

*Elegant and functional handlebar bag made of Cordura and natural leather with Moto Guzzi logo, useful to hold small items. Its functionality is guaranteed by the easy installation and removal from the vehicle handlebar.*



**BORSA SERBATOIO IN PELLE  
LEATHER TANK BAG**

.....  
COD. 2S000525

Borsa in pelle, estensibile, dotata di pratiche tasche e di maniglia per il trasporto, si fissa al copriserbatoio tramite sganci rapidi e chiusura micrometrica. È dotata di cuffia antipioggia.

*Extensible leather bag equipped with practical pockets and transport handle, fixed to the tank cover with quick release and micrometric closing. Includes rain cover.*



**KIT SUPPORTI LATERALI PER BORSE  
BAGS SUPPORT KIT**

.....  
COD. 2S000538

Kit di montaggio per le borse laterali in cuoio (cod. 2S000526).

*Mounting kit for the side leather bags (cod. 2S000526).*



**BAULETTO IN PELLE  
LEATHER REAR BAG**

.....  
COD. 2S000527

Bauletto posteriore in pelle nero con taglio classico, con capacità 30 lt, può essere montato al posto del sellino passeggero oppure sul portapacchi. Il sistema di sgancio a fettuccia consente di rimuovere velocemente le borse. Una cuffia impermeabile la protegge dalla pioggia.

*The rear classic-cut black leather top box, with 30 litre capacity, can be mounted in replacement of passenger seat, or on the rear rack. The strap release system allows to quickly remove the bags. A waterproof cover protects it against rain.*





**VALIGIE  
SIDE CASES**

.....  
COD. CM228701 NERO/BLACK

Valigie laterali verniciate nere, ciascuna presenta un volume di 35 lt.

*Side cases black painted each one has a volume of 35 liters.*



**KIT SUPPORTI VALIGIE  
SIDE CASES SUPPORT KIT**

.....  
COD. 2S000540

Kit di montaggio per le valigie rigide laterali, realizzato in materiale ad alta resistenza e trattato contro la corrosione e l'usura del tempo.

*Rigid side cases mounting kit, made in High resistant material, with anti-corrosion treatment to guarantee against weather conditions.*



**KIT SCARICHI OMOLOGATI  
HOMOLOGATED MUFFLERS SET**

.....  
COD. 2S000030

Per sentire il ruggito di una vera moto custom: questi scarichi slip on sono omologati e presentano uno stile simile agli scarichi di serie ma con una finitura dedicata e fondello specifico.

*To hear the roar of a real custom motorcycle: these slip on exhausts are approved and have a style similar to standard exhausts but with a dedicated finishing and specific ends caps.*



**KIT FONDELLI SCARICO  
EXHAUST ENDCUPS**

.....  
COD. B064289

Fondelli cromati per applicazione su scarico di serie, allungano il profilo dei silenziatori.

*The chromed end caps to be applied on the standard exhaust lengthen the profile of the mufflers.*



**BORSE RIVESTITE IN PELLE  
LEATHER SIDE CASES**

.....  
COD. B064239

Disegnate dal Centro Stile Moto Guzzi, rivestite in pelle naturale da artigiani specializzati. Realizzate a mano, sposano la linea originale della moto offrendo una personalizzazione ricercata, utilizzando pellami italiani di pregio.

*Side cases designed by Centro Stile Moto Guzzi, covered with genuine leather by professional craftsmen. The product is hand made and it is in line with the bike shape offering a sophisticated customization thanks to the fine Italian leathers used.*



**BORSE INTERNE PER VALIGIE  
LATERALI  
INNER BAGS FOR SIDE CASES**

.....  
COD. B064250

Costruite nella stessa forma delle valigie che le contengono, possono essere staccate e trasportate facilmente. Set realizzato con materiali altamente performanti e tecniche innovative che ne garantiscono impermeabilità e resistenza.

*Designed with the same shape of the bags containing them, they can be easily removed and be transported. This set of bags has been made in technical high performance materials, using innovative techniques that ensure resistance to water and all weather conditions.*



**KIT ALLARME ELETTRONICO  
ELECTRONIC ALARM KIT**

.....  
COD. 2D000027

Sistema di allarme compatto radiocomandato e autoalimentato di ultima generazione. Tra le sue specifiche offre: blocco motore, sensore di spostamento integrato, elevato livello di protezione.

*State of the art self-powered remote control compact alarm system. Its specifications include: engine block, built in motion sensor, high protection degree.*



**GUZZI MULTIMEDIA PLATFORM  
GUZZI MULTIMEDIA PLATFORM**

.....  
COD. 2S000157

GMP è il nuovo dispositivo che consente di collegare il proprio Smartphone alla moto, trasformandola in una vera e propria piattaforma multimediale. Per l'installazione utilizzare il supporto dedicato 2S000170.

*GMP is the new device that allows you to connect your smartphone to the motorcycle, turning it to a real multimedia platform. To mount it, use the dedicated bracket 2S000170.*





**KIT SUPPORTO CENTRALINA GMP  
GMP INSTALLATION KIT**

.....  
COD. 2S000156

Kit supporto dedicato al fissaggio del GMP, non necessita di cablaggi in quanto già predisposti nella moto.

*Dedicated bracket kit for fastening the GMP, does not require wiring harness since it is already provided on the motorcycle.*



**KIT SUPPORTO USB  
USB SOCKET KIT**

.....  
COD. 2S000315

Presse USB fornita di supporto dedicato per installazione nel sottosella, per la ricarica dei supporti elettronici, non consente il dialogo con gli apparati elettronici del mezzo.

*USB socket with bracket for installation under the saddle, to recharge the electronic media, does not allow dialogue with the electronic devices of the vehicle.*



**TELO COPRIMOTO  
ELDORADO "EAGLE"  
"EAGLE" ELDORADO BIKE COVER**

.....  
COD. 606167M  
COD. 606249M CON BAULE/WITH TOP BOX

Telo su misura da interno per la protezione dalla polvere da utilizzare durante le soste in garage della moto. È realizzato in un tessuto elasticizzato con grafica speciale.

*Tailor-made motorcycle cover for inside to protect against dust, intended for inside use to protect against dust, intended to be used for long period of storing of the bike in a garage. It is made of stretch fabric with special graphics.*





AUDACE



  
MOTO GUZZI®





**KIT SPECCHI "DARK"  
GAMBO ESTERNO  
EXTERNAL STEM MIRRORS  
KIT "DARK"**

.....  
COD. 2S000330

Realizzati in alluminio ricavato dal pieno, anodizzati neri, con il loro design semplice ma di tendenza contribuiscono a donare eleganza alla moto. Si applicano al posto dei terminali manubrio.

*Made of billet aluminium, black anodized, contribute with their clean but trendy design they add elegance to motorcycle look. Have to be mounted in replacement of handlebar ends.*



**KIT MANOPOLE "DARK"  
HANDGRIPS KIT "DARK"**

.....  
COD. 2S000334

Realizzate in alluminio ricavate dal pieno anodizzate nere, impreziosiscono il manubrio della moto donandole un look personalizzato ed elegante, sono predisposte per il montaggio dei terminali "Round".

*Made of black anodized billet aluminium, they enhance the handlebars of the motorcycle, providing it with a personalized and elegant look. They are ready to mount the "Round" ends.*



**TERMINALI MANOPOLE  
"CORSA" NERI  
GRIPS ENDPIPES "CORSA" BLACK**

.....  
COD. 2S000338

I terminali manopole "Corsa", realizzati in alluminio ricavato dal pieno anodizzati neri, si accoppiano alle manopole "Dark", realizzando un perfetto completamento stilistico ed estetico.

*The "Corsa" handlebar ends, made in black anodized billet aluminium, match the "dark" handlebar grips, achieving a perfect stylistic and aesthetic finishing.*



**TERMINALI MANOPOLE "CLASSIC"  
GRIPS ENDPIPES "CLASSIC"**

.....  
COD. 2S000341

I terminali manopole "Classic", realizzati in alluminio ricavato dal pieno, si accoppiano alle manopole standard, realizzando un perfetto completamento stilistico ed estetico.

*The "Classic" handlebar ends, made from billet aluminium, match the standard handlebars, achieving a perfect stylistic and aesthetic finishing.*



**KIT SPECCHI "DARK" GAMBO CORTO  
SHORT STEM MIRRORS KIT "DARK"**

.....  
COD. 2S000331

Realizzati in alluminio ricavato dal pieno, anodizzati neri, con il loro design semplice ma di tendenza contribuiscono a donare eleganza alla moto. La coppa specchio con gambo ribassato racchiude il massimo della tecnologia realizzativa che si esprime in alcune lavorazioni speciali realizzate sui tre assi. Sono omologati per tutti i paesi.

*Made of billet aluminium, black anodized, contribute with their clean but trendy design they add elegance to motorcycle look. Have to be mounted in replacement of handlebar ends. The mirror cover, with his lowered stem, express the maximum of technology capability with some exclusive works performed on tree axes. They are approved for all countries.*



**TERMINALI MANOPOLE  
"ROUND" NERI  
HANDLEBAR ENDPIPES  
"ROUND" BLACK**

.....  
COD. 2S000336

I terminali manopole "Round", realizzati in alluminio ricavato dal pieno anodizzati neri, si accoppiano alle manopole "Dark", realizzando un perfetto completamento stilistico ed estetico.

*The "Round" handlebar ends, made in black anodized billet aluminium, match the "dark" handlebar grips, achieving a perfect stylistic and aesthetic finishing.*



**LEVA FRIZIONE "DARK" NERA  
CLUTCH LEVER "DARK" BLACK**

.....  
COD. 2S000345

Realizzata in alluminio ricavata dal pieno, anodizzata nera, grazie alla sua consistenza ed alle sue regolazioni eleva il comfort di guida impreziosendo il look della moto.

*Made from billet aluminium, black anodized, due to its consistency and adjustments, it elevates the driving comfort giving a stylish look to the motorcycle.*



**LEVA FRENO ANTERIORE  
"DARK" NERA  
FRONT BRAKE LEVER "DARK" BLACK**

.....  
COD. 2S000344

Realizzata in alluminio ricavata dal pieno, anodizzata nera, grazie alla sua consistenza ed alle sue regolazioni eleva il comfort di guida impreziosendo il look della moto.

*Made in billet aluminium, black anodized, due to consistency and adjustability, elevate the driving comfort giving a stylish look to the motorcycle.*





**KIT COPERCHIO POMPA FRENO  
E FRIZIONE NERE**  
**BLACK BRAKE AND CLUTCH  
PUMP COVER KIT**  
.....

**COD. 25000464**

Speciali coperchi delle pompe freno e frizione realizzati in alluminio ricavati dal pieno anodizzati neri.

*Special covers of the brake pumps and clutch made from black anodized billet aluminium.*



**COVER SERBATOIO OLIO  
FRENO POSTERIORE**  
**BRAKE OIL TANK COVER**  
.....

**COD. B064288**

Realizzato in alluminio ricavato dal pieno, con una finitura lucida, personalizza il look del veicolo. Ricopre completamente il corpo del serbatoio olio freno lasciando inalterate le funzionalità. È di facile installazione.

*Made in billet aluminium, with polished finishing, it customize the look of the vehicle. It wrap completely the brake oil tank without compromise the function. Easy to mount.*



**GUANCIALI SERBATOIO  
CARBON LOOK**  
**CARBON LOOK TANK COVERS**  
.....

**COD. 606161M**

Le cover laterali del serbatoio rivestite con una speciale pellicola carbon look personalizzano lo stile della moto rendendola una vera «fuoriserie».

*The side tank covers, wrapped with special carbon-look film, customize the style of the motorcycle, making it a "custom-built" vehicle.*



**COVER TAPPO SERBATOIO  
CARBON LOOK**  
**CARBON LOOK TANK CAP COVER**  
.....

**COD. 606162M**

La cover del tappo del serbatoio rivestita con una speciale pellicola carbon look personalizza lo stile della moto rendendola una vera «fuoriserie».

*The cover of the tank tap, wrapped with special carbon-look film, customize the style of the motorcycle, making it a "custom-built" vehicle.*



**COVER TAPPI FORCELLA NERI**  
**BLACK FORK TOP CAPS COVER**  
.....

**COD. 25000400**

Realizzati in alluminio ricavato dal pieno anodizzati neri, facilmente installabili, sono stabilmente fissati alle viti che chiudono gli steli forcella mediante un piccolo grano in acciaio.

*Made in black anodized billet aluminium, these covers are easy to be mounted and strongly fixed to the fork top stems thanks to a small steel peg.*



**GUANCIALI SERBATOIO CROMATI**  
**CHROMED TANK COVERS**  
.....

**COD. B064244**

Le cover laterali del serbatoio cromate personalizzano lo stile della moto rendendola una vera «fuoriserie».

*The side tank covers, made of steel with chromed finish, customize the style of the motorcycle, making it a "custom-built" vehicle.*



**COPPIA COPRI-INIETTORI  
CARBON LOOK**  
**CARBON LOOK INJECTOR COVERS**  
.....

**COD. 606163M**

Le cover degli iniettori rivestite con una speciale pellicola carbon look personalizzano lo stile della moto rendendola una vera «fuoriserie».

*The injectors covers, wrapped with special carbon-look film, customize the style of the motorcycle, making it a true "custom-built" vehicle.*



**KIT PROTEZIONE TESTE**  
**CYLINDER COVERS PROTECTION KIT**  
.....

**COD. B064247**

Speciali protezioni laterali cilindri realizzate in alluminio ricavato dal pieno finite con la lucidatura a specchio. Si integrano perfettamente con lo stile ed il design della moto. Complete di supporti in acciaio inox lucidati a specchio.

*Special cylinder side shields made from billet aluminium, finished with high-gloss polishing. They perfectly match with style and design of the motorcycle. Provided with high-gloss polished stainless steel brackets.*





**KIT PARACALORE CILINDRI  
THERMAL PROTECTION SET**

.....  
COD. 2S000032

Ogni paracalore è realizzato in acciaio inox lucidato a specchio, con inserti in abs che migliorano il design ed attenuano il contatto delle ginocchia con il motore. Proteggono dal calore generato dal cilindro, per una guida più sicura e confortevole.

*Each heat shield is made from high-gloss polished stainless steel, with abs inserts improving the design and diminishing the contact of the knees with the engine. They protect from the heat generated by the cylinder, for a more secure and comfortable driving.*



**COVER FORI BASAMENTO  
MOTORE - NERO  
CRANKCASE ENGINE HOLES  
COVER - BLACK**

.....  
COD. 2S000399

Realizzati in alluminio tagliato al laser e anodizzati neri, consentono di coprire i fori di lavorazione di basamento del motore. La scritta "1400" realizzata al laser, esplica la cilindrata del veicolo.

*Made of polished laser-cut and black anodized aluminium, they cover the machining holes of the engine crankcase. The laser-engraved "1400" text denotes the cylinder capacity of the vehicle.*



**SET BUSSOLE TESTATA IN ALLUMINIO  
ALUMINIUM HEAD BUSHINGS SET**

.....  
COD. 2S000348

Set di quattro distanziali estetici in alluminio ricavato dal pieno, da montare in sostituzione delle viti che fissano le cover delle teste cilindro. Le viti a corredo sono in acciaio inox lucidato.

*Set of four aesthetic spacers made from billet aluminium, to be mounted in place of the screws that hold the cover of the cylinder head. The screws supplied with the vehicle are made of polished stainless steel.*



**ROSETTE FORCELLONE  
SWINGARM WASHERS**

.....  
COD. B064272

Rosette speciali realizzate in alluminio ricavate dal pieno per personalizzare lo stile della tua California.

*Special washers made of billet aluminium to personalize the style of your California.*



**COVER TESTE CILINDRO - ROSSO  
OPACO  
CYLINDERS COVERS KIT - MATT RED**

.....  
COD. 2S000363

Eleganti cover teste cilindro verniciate, con speciali lavorazioni eseguite in fresatura, rappresentano uno speciale elemento di personalizzazione del veicolo.

*Elegant painted cylinder heads covers, with special processes performed in milling, they represent a special element of customization to the vehicle.*



**COVER TESTE CON LAVORAZIONE  
GRIGIO  
CYLINDERS COVERS KIT - GREY**

.....  
COD. 2S000364

Eleganti cover teste cilindro verniciate, con speciali lavorazioni eseguite in fresatura, rappresentano uno speciale elemento di personalizzazione del veicolo.

*Elegant painted cylinder heads covers, with special processes performed in milling, they represent a special element of customization to the vehicle.*



**COVER CLACSON  
IN ALLUMINIO NERI  
BLACK ALUMINIUM HORNS COVERS**

.....  
COD. 2S000462

Cover in alluminio ricavato dal pieno anodizzate nere, si applicano ai clacson per dare un look sportivo alla moto.

*Cover made from billet aluminium black anodized, applied on the horns they give a sportive look to the motorcycle.*



**PEDANE PILOTA IN ALLUMINIO  
ALUMINIUM RIDER FOOTREST**

.....  
COD. 2S000346

Pregevoli cover in alluminio ricavate dal pieno, si montano in sostituzione della gomma montata di serie. Le fresature realizzano un disegno specifico e garantiscono il massimo grip in ogni condizione di guida.

*Fine covers from billet aluminium, they are mounted in replacement of the standard rubbers. The milling draws a specific design to guarantee the maximum grip in all driving conditions.*





**PEDANE PASSEGGERO IN ALLUMINIO  
ALUMINIUM PASSENGER FOOTREST**

.....  
COD. 2S000347

Pregevoli cover in alluminio ricavate dal pieno, si montano in sostituzione della gomma montata di serie. Le fresature realizzano un disegno specifico e garantiscono il massimo grip in ogni condizione di guida.

*Fine covers from billet aluminium, they are mounted in replacement of the standard rubbers. The milling draws a specific design to guarantee the maximum grip in all driving conditions.*



**PORTA TARGA  
PLATE SUPPORT**

.....  
COD. B064254  
COD. 2S000033 USA

Elegante portatarga omologato realizzato in acciaio inox con finiture lucide.

*Elegant approved plate holder made of stainless steel with glossy finishing.*



**KIT SUPPORTO CENTRALINA GMP  
GMP INSTALLATION KIT**

.....  
COD. 2S000156

Kit supporto dedicato al fissaggio del GMP, non necessita di cablaggi in quanto già predisposti nella moto.

*Dedicated bracket kit for fastening the GMP, does not require wiring harness since it is already provided on the motorcycle.*



**KIT SUPPORTO USB  
USB SOCKET KIT**

.....  
COD. 2S000315

Presse USB fornita di supporto dedicato per installazione nel sottosella, per la ricarica dei supporti elettronici, non consente il dialogo con gli apparati elettronici del mezzo.

*USB socket with bracket for installation under the saddle, to recharge the electronic media, does not allow dialogue with the electronic devices of the vehicle.*



**KIT ALLARME ELETTRONICO  
ELECTRONIC ALARM KIT**

.....  
COD. 2D000027

Sistema di allarme compatto radiocomandato e autoalimentato di ultima generazione. Tra le sue specifiche offre: blocco motore, sensore di spostamento integrato, elevato livello di protezione.

*State of the art self-powered remote control compact alarm system. Its specifications include: engine block, built in motion sensor, high protection degree.*



**GUZZI MULTIMEDIA PLATFORM  
GUZZI MULTIMEDIA PLATFORM**

.....  
COD. 2S000157

GMP è il nuovo dispositivo che consente di collegare il proprio Smartphone alla moto, trasformandola in una vera e propria piattaforma multimediale. Per l'installazione utilizzare il supporto dedicato 2S000170.

*GMP is the new device that allows you to connect your smartphone to the motorcycle, turning it to a real multimedia platform. To mount it, use the dedicated bracket 2S000170.*



**TELO COPRIMOTO AUDACE EAGLE  
"EAGLE" AUDACE BIKE COVER**

.....  
COD. 606166M

Telo su misura da interno per la protezione dalla polvere da utilizzare durante le soste in garage della moto. È realizzato in un tessuto elasticizzato con grafica speciale.

*Tailor-made motorcycle cover for inside to protect against dust, intended for use during long periods of storing the bike in a garage. It is made of stretch fabric with special graphics.*





CALIFORNIA

1400 TOURING SE

  
MOTO GUZZI®





**PARABREZZA MEDIO  
SUPPORTI RIBASSATI  
MEDIUM WINDSHIELD  
LOWER BRACKETS**

.....  
COD. 2S000544

Parabrezza di misura media con la lastra in Lexan antiurto e antigraffio. Omologato secondo le normative DOT. Si monta facilmente grazie ai supporti ribassati da acquistare separatamente. H44 x L52 cm.

*Medium sized windshield with shockproof and scratch resistant Lexan sheet. Approved according to the DOT standards. It is easy to mount due to its lowered brackets, to be purchased separately. H44 x L52 cm.*



**KIT SUPPORTI PARABREZZA  
RIBASSATI  
WINDSHIELD LOWER BRACKETS KIT**

.....  
COD. 2S000542

Robusto kit di fissaggio, a misura ridotta, dotato di supporti specifici per il montaggio del parabrezza.

*Small sized solid fastening kit, equipped with specific brackets for mounting the windshield.*



**PARABREZZA GRANDE  
SUPPORTI STANDARD  
WIDE WINDSCREEN  
STANDARD BRACKETS**

.....  
COD. 2S000547

Parabrezza di misura grande con la lastra in Lexan antiurto e antigraffio. Omologato secondo le normative DOT. Si monta facilmente grazie ai supporti standard da acquistare separatamente. H70 x L59 cm.

*Large sized windshield with shockproof and scratch resistant Lexan sheet. Approved according to the DOT standards. Can be easily mounted due to the standard brackets, to be purchased separately. H70 x L59 cm.*



**KIT COPERCHIO POMPA  
FRENO E FRIZIONE  
BRAKE AND CLUTCH PUMP  
COVER KIT**

.....  
COD. B064259

Speciali coperchi delle pompe freno e frizione realizzati in alluminio ricavati dal pieno con finitura antigraffio lucida. Special covers for brake and clutch pumps made from billet aluminium with glossy scratch resistant finishing.



**PARABREZZA SPORT  
SUPPORTI RIBASSATI  
SPORT WINDSHIELD  
LOWER BRACKETS**

.....  
COD. 2S000548

Parabrezza di misura particolarmente ridotta con la lastra in Lexan antiurto e antigraffio, che mantiene nel tempo inalterate le caratteristiche di trasparenza e lucentezza. Omologato secondo le normative DOT. Si monta facilmente grazie ai supporti ribassati da acquistare separatamente. H34 x L41 cm.

*Specially reduced sized windshield with shockproof and scratch resistant Lexan sheet, maintaining the transparency and gloss characteristics unaltered over time. Approved according to the DOT standards. It is easy to mount due to its lowered brackets, to be purchased separately. H34 x L41 cm.*



**PARABREZZA MEDIO  
SUPPORTI STANDARD  
COUPLE MIRROR**

.....  
COD. 2S000546

Parabrezza di misura media con la lastra in Lexan antiurto e antigraffio. Il Lexan è omologato secondo le ferree normative DOT americane. Si monta facilmente grazie ai supporti standard da acquistare separatamente. H44 x L52 cm.

*Medium sized windshield with shockproof and scratch resistant Lexan sheet. Lexan is approved according to the strict American DOT regulations. Can be easily mounted due to the standard brackets, to be purchased separately. H44 x L52 cm.*



**SPECCHIETTI RETROVISORI  
MIRRORS**

.....  
COD. B064245

Speciali specchietti retrovisori omologati realizzati in alluminio ricavati dal pieno con finitura antigraffio lucida.

*Special approved rear-view mirrors made of billet aluminium with glossy scratch resistant finishing.*



**SPECCHIETTI RETROVISORI NERI  
BLACK MIRRORS**

.....  
COD. 2S000031

Speciali specchietti retrovisori omologati realizzati in alluminio ricavato dal pieno con finitura nera.

*Special approved rear-view mirrors made of billet aluminium with black finishing.*





**LEVA FRIZIONE  
CLUTCH LEVER**

.....  
COD. B064256

Speciale leva della frizione regolabile realizzata in alluminio, ricavata dal pieno con design personalizzato e con finitura antigraffio lucida.

*Special adjustable clutch lever made of billet aluminium, with custom design and glossy scratch resistant finishing.*



**LEVA FRENO  
BRAKE LEVER**

.....  
COD. B064255

Speciale leva del freno regolabile realizzata in alluminio, ricavata dal pieno con design personalizzato e con finitura antigraffio lucida.

*Special adjustable brake lever made of billet aluminium, with custom design and glossy scratch resistant finishing.*



**SUPPORTO GPS  
GPS BRACKET**

.....  
COD. B064243

Supporto realizzato in acciaio inox lucido con predisposizione per il montaggio del navigatore satellitare.

*Bracket made of glossy stainless steel bracket for Navigation system connection on the handlebar.*



**COVER SERBATOIO OLIO FRENO  
POSTERIORE  
BRAKE OIL TANK COVER**

.....  
COD. B064288

Realizzato in alluminio ricavato dal pieno, con una finitura lucida, personalizza il look del veicolo.

Ricopre completamente il corpo del serbatoio olio freno lasciando inalterate le funzionalità. È di facile installazione.

*Made from billet aluminium, with a polished finish, it customizes the look of the vehicle.*

*Covers completely the body of the brake oil tank, without altering the functions. Easy to mount.*



**MANOPOLE IN ALLUMINIO  
ALUMINIUM HANDGRIPS**

.....  
COD. B064257

Speciali manopole realizzate in alluminio ricavate dal pieno con inserti anti scivolo in gomma e finitura lucida.

*special billet aluminium handlebar grips with rubber inserts and glossy finishing.*



**MANOPOLE RISCALDATE  
HEATED HANDGRIPS**

.....  
COD. B064270

Per chi ama viaggiare a lungo in tutte le stagioni, facilmente installabili grazie alla predisposizione presente su tutte le California. Contribuiscono al comfort di guida, evitando che le mani possano indolenzirsi a causa del freddo.

*For those who love travelling in all seasons, easily mountable due to the arrangement on all California. They contribute to the driving comfort, preventing hand stiffening because of the cold.*



**MANUBRIO TOURING  
CROMATO NERO  
BLACK CHROMED  
HANDLEBAR TOURING**

.....  
COD. B064246

Per una personalizzazione esclusiva della propria moto, sviluppato dai collaudatori Moto Guzzi, il manubrio cromato nero consente di mantenere la posizione di guida ottimale per il controllo della moto. Da oliare periodicamente per proteggere e mantenere lucida la cromatura.

*For an exclusive customization of your motorcycle, developed by the Moto Guzzi testers, the black chrome handlebar keeps the optimum driving position for the control of the motorcycle. To be oiled regularly to protect and maintain the gloss of the chromium coating.*



**GUANCIALI SERBATOIO CROMATI  
CHROMED TANK COVERS**

.....  
COD. B064244

Le cover laterali del serbatoio cromate personalizzano lo stile della moto rendendola una vera "fuoriserie".

*The side tank covers, made of steel with chromed finish, customize the style of the motorcycle, making it a "custom-built" vehicle.*





**SET BUSSOLE TESTATA IN ALLUMINIO  
ALUMINIUM HEAD BUSHINGS SET**

.....  
COD. 2S000348

Set di quattro distanziali in alluminio ricavato dal pieno, da montare in sostituzione delle viti che fissano le cover delle teste cilindro. Le viti a corredo sono in acciaio inox lucidato.

*Set of four aesthetic spacers made from billet aluminium, to be mounted in place of the screws that hold the cover of the cylinder head. The screws supplied with the kit are made of polished stainless steel.*



**COPRI INIETTORI  
INJECTOR COVERS**

.....  
COD. B064253

La coppia di copri iniettori realizzati in alluminio con finitura spazzolata sostituisce quella di serie, assicurando alla moto un look più ricco, più curato e coerente con le parti in alluminio già presenti.

*The injector covers made of aluminium with brushed finishing replaces the standard one, providing the motorcycle with a richer, refined and consistent look with the aluminium parts already mounted.*



**SELLA IN PELLE TOURING  
TOURING LEATHER SADDLE**

.....  
COD. B064237

Per chi ricerca una finitura di lusso che sposi lo stile pregiato offerto dalla moto è disponibile una sella rivestita in vera pelle da artigiani specializzati.

*For those looking for a luxurious finishing matching the refined style offered by this motorcycle, we offer a special saddle, covered of true leather by skilled artisans.*



**SELLA COMFORT TOURING  
TOURING COMFORT SADDLE**

.....  
COD. B064236

Comfort offerto a pilota e passeggero grazie agli inserti in gel ricavati nelle zone di seduta. Materiale bicolore in linea con l'allestimento top della moto. Dicitura «comfort gel» punzonata in rilievo. Stessa altezza della sella di serie.

*Comfort for the driver and passenger thanks to the gel inserts in the saddle. Bi-coloured material in line with the top equipment of the motorcycle. "Comfort gel" text engraved in relief. Same height as the standard series.*



**KIT PROTEZIONE TESTE  
CYLINDER COVERS PROTECTION KIT**

.....  
COD. B064247

Speciali protezioni laterali cilindri realizzate in alluminio ricavato dal pieno finite con la lucidatura a specchio. Si integrano perfettamente con lo stile ed il design della moto. Complete di supporti in acciaio inox lucidati a specchio.

*Special cylinder side shields made from billet aluminium, finished with high-gloss polishing. They perfectly match with style and design of the motorcycle. Provided with high-gloss polished stainless steel brackets.*



**KIT PARACALORE CILINDRI  
THERMAL PROTECTION SET**

.....  
COD. 2S000032

Ogni paracalore è realizzato in acciaio inox lucidato a specchio, con inserti in abs che migliorano il design ed attenuano il contatto delle ginocchia con il motore. Proteggono dal calore generato dal cilindro, per una guida più sicura e confortevole.

*Each heat shield is made from high-gloss polished stainless steel, with abs inserts improving design and reducing the contact of the knees with the engine. They protect from the heat generated by the cylinder, for a more secure and comfortable driving.*



**SELLA RIBASSATA COMFORT TOURING  
TOURING COMFORT LOWER SADDLE**

.....  
COD. B064238

Sella che unisce il comfort del gel alla comodità del profilo rivisto e ribassato per un migliore e più sicuro appoggio a terra. Lo stesso comfort è offerto al passeggero. Rifinita con materiale bicolore, arricchita con dicitura «comfort gel».

*This saddle combines the comfort provided by gel inserts with additional control of the bike provided by a lowered seat. The passenger benefits of the same comfort. Refinished with bi-coloured material, enriched with the text "comfort gel".*



**ROSETTE FORCELLONE  
SWINGARM WASHERS**

.....  
COD. B064272

Rosette speciali realizzate in alluminio ricavate dal pieno per personalizzare lo stile della tua California.

*Special washers made of billet aluminium to personalize the style of your California.*





**PEDANE PILOTA  
PILOT FOOTRESTS**

.....  
COD. B064249

Pedane pilota reclinabili realizzate in alluminio ricavato dal pieno lucidate a specchio, mantengono la stessa ergonomia di guida di quelle di serie ma offrono un design alleggerito e personalizzato in linea con lo stile della moto.

*Reclining rider footpegs made of high-gloss polished billet aluminium, they maintain the same driving ergonomics like the standard ones, but offer a light-weight and customized design in line with the style of the motorcycle.*



**PEDANE PASSEGGERO  
PASSENGER FOOTRESTS**

.....  
COD. B064248

Realizzate in alluminio ricavato dal pieno lucidate a specchio. Mantengono lo stesso design delle pedane pilota. Regolabili orizzontalmente in quattro posizioni attraverso un meccanismo a molla che facilita il loro posizionamento ottimale.

*Made of high-gloss polished billet aluminium. Maintain the same design of the rider footpegs. Horizontally adjustable in four positions by means of the spring mechanism that facilitates their ideal positioning.*



**BORSA SERBATOIO  
TANKBAG**

.....  
COD. 2S000039

Borsa in Cordura con inserti in pelle, estensibile, dotata di pratiche tasche e di maniglia per il trasporto, si fissa al copri serbatoio tramite sganci rapidi e chiusura micrometrica. È dotata di cuffia anti-pioggia.

*Extensible Cordura bag with leather inserts, equipped with practical pockets and transport handle, applied to the tank cover by quick release clamps and micrometric closing. Includes rain cover.*



**PORTAPACCHI  
REAR RACK**

.....  
COD. B063992

Disegnato in tubo cromato dal Centro Stile Moto Guzzi, questo portapacchi amplia la capacità di carico della moto consentendo il montaggio dei bauli accessorio dedicati grazie alle apposite predisposizioni di fissaggio.

*Designed in chrome tube by Centro Stile Moto Guzzi, it expands the load capacity of the motorcycle, allowing to mount dedicated accessory cases thanks to the special fixing arrangements.*



**BORSA MANUBRIO  
HANDLEBAR BAG**

.....  
COD. 2S000034

Elegante e funzionale borsa-manubrio realizzata in cordura e pelle naturale che incornicia il marchio Moto Guzzi, utile per contenere piccoli oggetti. La sua funzionalità è garantita dalla facile installazione e rimozione dal manubrio del veicolo.

*Elegant and functional handlebar bag made of Cordura and natural leather with Moto Guzzi logo, useful to hold small items. Its functionality is guaranteed by the easy installation and removal from the vehicle handlebar.*



**COPRI SERBATOIO  
TANK COVER**

.....  
COD. 2S000038

Realizzato in Cordura con inserti in pelle, permette di montare la borsa serbatoio dedicata.

*Made of Cordura with leather inserts, allows mounting the dedicated tank bag.*



**BAULETTO NERO 50 LT CON CUSCINO  
50 LT BLACK TOP BOX**

.....  
COD. CM228501

Baule da 50 lt. a sgancio rapido, può ospitare 2 caschi integrali. Guscio superiore verniciato in tinta veicolo, dotato di schienalino rifinito nei materiali e colore della sella. Dotato di tasca portadocumenti ed elastico ferma-oggetti. Necessita di portapacchi B063992.

*50 litres box with quick release system, can hold 2 flip up helmets. Upper cover painted in the colour of the vehicle, equipped with backrest refinished with fabric in the same colour of the saddle. Equipped with document holder pocket with object holder rubber band. Requires luggage carrier B063992.*



**BAULE 65 LT CON CUSCINO  
65 LT TOP CASE**

.....  
COD. CM262803 MARRONE/BROWN  
COD. CM262804 GRIGIO/GREY  
COD. CM262805 ROSSO/RED

Baule in vetroresina da 65 lt, verniciato in tinta veicolo con serrature cromate. Il suo interno è rifinito in vellutino, ed è dotato di specchio, rete salvaoggetti e pistone, che lo rendono funzionale, piacevole e distintivo. Necessita di portapacchi B063992.

*65 litre fibreglass top box, painted in the same color of the vehicle, with chrome locks. The inside has a anti-scratch velvet surface, a mirror and a opening leverage that make the use of this top box very functional, enjoyable and distinctive. Requires luggage carrier B063992.*





**BORSE RIVESTITE IN PELLE  
LEATHER SIDE CASES**

.....  
COD. B064239

Disegnate dal Centro Stile Moto Guzzi, rivestite in pelle naturale da artigiani specializzati. Realizzate a mano, sposano la linea originale della moto offrendo una personalizzazione ricercata, utilizzando pellami italiani di pregio.

*Designed by the Moto Guzzi Style Centre, coated with natural leather by skilled artisans. Manually crafted, they match the original line of the motorcycle, offering a refined personalized aspect, using prestigious Italian leathers.*



**BORSE INTERNE PER VALIGIE  
LATERALI  
INNER BAGS FOR SIDE CASES**

.....  
COD. B064250

Costruite nella stessa forma delle valigie che le contengono, possono essere staccate e trasportate facilmente. Set realizzato con materiali altamente performanti e tecniche innovative che ne garantiscono impermeabilità e resistenza.

*Designed with the same shape of the cases containing them, they can be easily removed and carried. Set made of high-performance materials and innovative techniques guaranteeing water tightness and resistance.*



**PORTA TARGA  
PLATE SUPPORT**

.....  
COD. B064254  
COD. 2S000033 USA

Elegante portatarga omologato realizzato in acciaio inox con finiture lucide.

*Elegant approved plate holder made of stainless steel with glossy finishing.*



**ALLARME ELETTRONICO  
ELECTRONIC ALARM**

.....  
COD. 2D000027

Sistema di allarme compatto radiocomandato e autoalimentato di ultima generazione. Tra le sue specifiche offre: blocco motore, sensore di spostamento integrato, elevato livello di protezione.

*State of the art self-powered remote control compact alarm system. Its specifications include: engine block, built in motion sensor, high protection degree.*



**KIT SCARICHI OMOLOGATI  
HOMOLOGATED MUFFLERS SET**

.....  
COD. 2S000030

Per sentire il ruggito di una vera moto custom: questi scarichi slip on sono omologati e presentano uno stile simile agli scarichi di serie ma con una finitura dedicata e fondello specifico.

*To hear the roar of a true custom motorcycle: These slip on exhausts are approved and have a style similar to standard exhausts but with a dedicated finishing and specific back cover.*



**FONDELLI SCARICO  
EXHAUST ENDCUPS**

.....  
COD. B064289

Speciali fondelli da applicare allo scarico di serie per personalizzare lo stile del veicolo. L'involucro esterno è realizzato in acciaio inox lucidato a specchio mentre il terminale interno è realizzato in alluminio ricavato dal pieno con finitura lucida.

*Special end caps to be applied to the standard exhaust to personalize the style of the vehicle. The outer casing is made of high-gloss polished stainless steel while the internal end part is made of billet aluminium with polished finishing.*



**GUZZI MULTIMEDIA PLATFORM  
GUZZI MULTIMEDIA PLATFORM**

.....  
COD. 2S000157

GMP è il nuovo dispositivo che consente di collegare il proprio Smartphone alla moto, trasformandola in una vera e propria piattaforma multimediale. Per l'installazione utilizzare il supporto dedicato 2S000170.

*GMP is the new device that allows you to connect your smartphone to the motorcycle, turning it to a real multimedia platform. To mount it, use the dedicated bracket 2S000170.*



**KIT SUPPORTO CENTRALINA GMP  
GMP INSTALLATION KIT**

.....  
COD. 2S000156

Kit supporto dedicato al fissaggio del GMP, non necessita di cablaggi in quanto già predisposti nella moto.

*Dedicated bracket kit for fastening the GMP, does not require wiring harness since it is already provided on the motorcycle.*





**KIT SUPPORTO USB**  
**USB SOCKET KIT**  
 .....  
 COD. 2S000315

Presse USB fornita di supporto dedicato per installazione nel sottosella, per la ricarica dei supporti elettronici, non consente il dialogo con gli apparati elettronici del mezzo.

*USB socket with bracket for installation under the saddle, to recharge the electronic media, does not allow dialogue with the electronic devices of the vehicle.*



**TELO COPRIMOTO TOURING**  
**CON BAULE**  
**TOURING BIKE COVER WITH TOP BOX**  
 .....  
 COD. B064242

Telo su misura da interno per la protezione dalla polvere da utilizzare durante le soste in garage della moto. È realizzato in un tessuto elasticizzato bicolore con grafica dedicata.

*Tailor-made motorcycle cover for inside to protect against dust, intended for use during long periods of storing the bike in a garage. It is made from an elasticised bi-coloured fabric with dedicated graphics.*





# CALIFORNIA

1400 TOURING







**PARABREZZA MEDIO  
SUPPORTI RIBASSATI  
MEDIUM WINDSHIELD  
LOWER BRACKETS**

.....  
COD. 2S000544

Parabrezza di misura media con la lastra in Lexan antiurto e antigraffio. Omologato secondo le normative DOT. Si monta facilmente grazie ai supporti ribassati da acquistare separatamente. H44 x L52 cm.

*Medium sized windshield with shockproof and scratch resistant Lexan sheet. Approved according to the DOT standards. It is easy to mount due to its lowered brackets, to be purchased separately. H44 x L52 cm.*



**KIT SUPPORTI PARABREZZA  
RIBASSATI  
WINDSHIELD LOWER BRACKETS KIT**

.....  
COD. 2S000542

Robusto kit di fissaggio, a misura ridotta, dotato di supporti specifici per il montaggio del parabrezza.

*Small sized solid fastening kit, equipped with specific brackets for mounting the windshield.*



**DEFLETTORI ARIA PARABREZZA  
WINDSHIELD AIR DEFLECTORS**

.....  
COD. B064235

Appendici da applicare nella zona sottostante al parabrezza per aumentare la protezione ed il comfort di guida offerti al pilota.

*Attachments to be applied under the windshield to increase rider's protection and driving comfort.*



**PARABREZZA GRANDE  
SUPPORTI STANDARD  
WIDE WINDSCREEN  
STANDARD BRACKETS**

.....  
COD. 2S000547

Parabrezza di misura grande con la lastra in Lexan antiurto e antigraffio. Omologato secondo le normative DOT. Si monta facilmente grazie ai supporti standard da acquistare separatamente. H70 x L59 cm.

*Large sized windshield with shockproof and scratch resistant Lexan sheet. Approved according to the DOT standards. Can be easily mounted due to the standard brackets, to be purchased separately. H70 x L59 cm.*



**PARABREZZA SPORT  
SUPPORTI RIBASSATI  
SPORT WINDSHIELD  
LOWER BRACKETS**

.....  
COD. 2S000548

Parabrezza di misura particolarmente ridotta con la lastra in Lexan antiurto e antigraffio, che mantiene nel tempo inalterate le caratteristiche di trasparenza e lucentezza. Omologato secondo le normative DOT. Si monta facilmente grazie ai supporti ribassati da acquistare separatamente. H34 x L41 cm.

*Specially reduced sized windshield with shockproof and scratch resistant Lexan sheet, maintaining the transparency and gloss characteristics unaltered over time. Approved according to the DOT standards. It is easy to mount due to its lowered brackets, to be purchased separately. H34 x L41 cm.*



**PARABREZZA MEDIO  
SUPPORTI STANDARD  
MEDIUM WINDSCREEN  
STANDARD BRACKETS**

.....  
COD. 2S000546

Parabrezza di misura media con la lastra in Lexan antiurto e antigraffio, che mantiene nel tempo inalterate le caratteristiche di trasparenza e lucentezza. Omologato secondo le normative DOT. Si monta facilmente grazie ai supporti standard da acquistare separatamente. H44 x L52 cm.

*Medium sized windshield with shockproof and scratch resistant Lexan sheet, maintaining the transparency and gloss characteristics unaltered over time. Approved according to the DOT standards. Can be easily mounted due to the standard brackets, to be purchased separately. H44 x L52 cm.*



**SPECCHIETTI RETROVISORI  
MIRRORS**

.....  
COD. B064245

Speciali specchietti retrovisori omologati realizzati in alluminio ricavati dal pieno con finitura antigraffio lucida.

*Special approved rear-view mirrors made of billet aluminium with glossy scratch resistant finishing.*



**SPECCHIETTI RETROVISORI NERI  
BLACK MIRRORS**

.....  
COD. 2S000031

Speciali specchietti retrovisori omologati realizzati in alluminio ricavato dal pieno con finitura nera.

*Special approved rear-view mirrors made of billet aluminium with black finishing.*





**LEVA FRIZIONE  
CLUTCH LEVER**

.....  
COD. B064256

Speciale leva della frizione regolabile realizzata in alluminio, ricavata dal pieno con design personalizzato e con finitura antigraffio lucida.

*Special adjustable clutch lever made of billet aluminium, with custom design and glossy scratch resistant finishing.*



**LEVA FRENO  
BRAKE LEVER**

.....  
COD. B064255

Speciale leva del freno regolabile realizzata in alluminio, ricavata dal pieno con design personalizzato e con finitura antigraffio lucida.

*Special adjustable brake lever made of billet aluminium, with custom design and glossy scratch resistant finishing.*



**MANOPOLE RISCALDATE  
HEATED HANDGRIPS**

.....  
COD. B064270

Per chi ama viaggiare a lungo in tutte le stagioni, facilmente installabili grazie alla predisposizione presente su tutte le California. Contribuiscono al comfort di guida, evitando che le mani possano indolenzirsi a causa del freddo.

*For those who love travelling in all seasons, easily mountable due to the arrangement on all California. They contribute to the driving comfort, preventing hand stiffening because of the cold.*



**SUPPORTO GPS  
GPS BRACKET**

.....  
COD. B064243

Supporto realizzato in acciaio inox lucido con predisposizione per il montaggio del navigatore satellitare.

*Bracket made of glossy stainless steel with arrangement for mounting the satellite navigator.*



**KIT COPERCHIO POMPA  
FRENO E FRIZIONE  
BRAKE AND CLUTCH PUMP  
COVER KIT**

.....  
COD. B064259

Speciali coperchi delle pompe freno e frizione realizzati in alluminio ricavati dal pieno con finitura antigraffio lucida.

*Special covers for brake and clutch pumps made from billet aluminium with glossy scratch resistant finishing.*



**MANOPOLE IN ALLUMINIO  
ALUMINIUM HANDGRIPS**

.....  
COD. B064257

Speciali manopole realizzate in alluminio ricavate dal pieno con inserti anti scivolo in gomma e finitura lucida.

*Special billet aluminium handlebars with rubber non-skid inserts and glossy finishing.*



**COVER SERBATOIO OLIO FRENO  
POSTERIORE  
BRAKE OIL TANK COVER  
BLACK CHROME**

.....  
COD. B064288

Realizzato in alluminio ricavato dal pieno, con una finitura lucida, personalizza il look del veicolo. Ricopre completamente il corpo del serbatoio olio freno lasciando inalterate le funzionalità. È di facile installazione.

*Made from billet aluminium, with a polished finish, it customizes the look of the vehicle. Covers completely the body of the brake oil tank, without altering the functions. Easy to mount.*



**COPRI STELI FORCELLA  
FORK SLEEVE COVERS**

.....  
COD. B064252

I copri steli forcella con finitura cromata si abbinano agli altri elementi in alluminio, già presenti sul veicolo, per esaltare le zone laterali.

*The fork sleeve covers with chrome finishing match the other aluminium elements, already mounted on the vehicle, to enhance the side areas.*





**MANUBRIO TOURING CROMATO NERO  
BLACK CHROMED HANDLEBAR TOURING**

.....  
COD. B064246

Per una personalizzazione esclusiva della propria moto, sviluppato dai collaudatori Moto Guzzi, il manubrio cromato nero consente di mantenere la posizione di guida ottimale per il controllo della moto. Da oliare periodicamente per proteggere e mantenere lucida la cromatura.

*For an exclusive customization of your motorcycle, developed by the Moto Guzzi testers, the black chrome handlebar keeps the optimum driving position for the control of the motorcycle. To be oiled regularly to protect and maintain the gloss of the chromium coating.*



**GUANCIALI SERBATOIO CROMATI  
CHROMED TANK COVERS**

.....  
COD. B064244

Le cover laterali del serbatoio cromate personalizzano lo stile della moto rendendola una vera «fuoriserie».

*The side tank covers, made of steel with chromed finish, customize the style of the motorcycle, making it a "custom-built" vehicle.*



**KIT PROTEZIONE TESTE  
CYLINDER COVERS PROTECTION KIT**

.....  
COD. B064247

Speciali protezioni laterali cilindri realizzate in alluminio ricavato dal pieno finite con la lucidatura a specchio. Si integrano perfettamente con lo stile ed il design della moto. Complete di supporti in acciaio inox lucidati a specchio.

*Special cylinder side shields made from billet aluminium, finished with high-gloss polishing. They perfectly match with style and design of the motorcycle. Provided with high-gloss polished stainless steel brackets.*



**KIT PARACALORE CILINDRI  
THERMAL PROTECTION SET**

.....  
COD. 2S000032

Ogni paracalore è realizzato in acciaio inox lucidato a specchio, con inserti in abs che migliorano il design ed attenuano il contatto delle ginocchia con il motore. Proteggono dal calore generato dal cilindro, per una guida più sicura e confortevole.

*Each heat shield is made from high-gloss polished stainless steel, with abs inserts improving design and reducing the contact of the knees with the engine. They protect from the heat generated by the cylinder, for a more secure and comfortable driving.*



**SET BUSSOLE TESTATA IN ALLUMINIO  
ALUMINIUM HEAD BUSHINGS SET**

.....  
COD. 2S000348

Set di quattro distanziali in alluminio ricavato dal pieno, da montare in sostituzione delle viti che fissano le cover delle teste cilindro. Le viti a corredo sono in acciaio inox lucidato.

*Set of four aesthetic spacers made from billet aluminium, to be mounted in place of the screws that hold the cover of the cylinder head. The screws supplied with the kit are made of polished stainless steel.*



**COPRI INIETTORI  
INJECTOR COVERS**

.....  
COD. B064253

La coppia di copri iniettori realizzati in alluminio con finitura spazzolata sostituisce quella di serie, assicurando alla moto un look più ricco, più curato e coerente con le parti in alluminio già presenti.

*The injector covers made of aluminium with brushed finishing replaces the standard one, providing the motorcycle with a richer, refined and consistent look with the aluminium parts already mounted.*



**SELLA IN PELLE TOURING  
TOURING LEATHER SADDLE**

.....  
COD. B064237

Per chi ricerca una finitura di lusso che sposi lo stile pregiato offerto dalla moto è disponibile una sella rivestita in vera pelle da artigiani specializzati.

*For those looking for a luxurious finishing matching the refined style offered by the motorcycle, a saddle covered with true leather by skilled artisans.*



**SELLA COMFORT TOURING  
TOURING COMFORT SADDLE**

.....  
COD. B064236

Comfort offerto a pilota e passeggero grazie agli inserti in gel ricavati nelle zone di seduta. Materiale bicolore in linea con l'allestimento top della moto. Dicitura "comfort gel" punzonata in rilievo. Stessa altezza della sella di serie.

*Comfort for the driver and passenger thanks to the gel inserts in the saddle. Bi-coloured material in line with the top equipment of the motorcycle. "Comfort gel" text engraved in relief «comfort gel». Same height as the standard series.*





**SELLA RIBASSATA COMFORT TOURING  
TOURING COMFORT LOWER SADDLE**

.....  
COD. B064238

Sella che unisce il comfort del gel alla comodità del profilo rivisto e ribassato per un migliore e più sicuro appoggio a terra. Lo stesso comfort è offerto al passeggero. Rifinita con materiale bicolore, arricchita con dicitura "comfort gel".

*Saddle that unites the comfort provided by gel and the convenience offered by the revised and lowered profile for a better and safer contact with the ground. The passenger benefits of the same comfort. Refinished with bi-coloured material, enriched with the text "comfort gel".*



**ROSETTE FORCELLONE  
SWINGARM WASHERS**

.....  
COD. B064272

Rosette speciali realizzate in alluminio ricavate dal pieno per personalizzare lo stile della tua California.

*Special washers made of billet aluminium to personalize the style of your California.*



**BORSA MANUBRIO  
HANDLEBAR BAG**

.....  
COD. 2S000034

Elegante e funzionale borsa-manubrio realizzata in cordura e pelle naturale che incornicia il marchio Moto Guzzi, utile per contenere piccoli oggetti. La sua funzionalità è garantita dalla facile installazione e rimozione dal manubrio del veicolo.

*Elegant and functional handlebar bag made of Cordura and natural leather with Moto Guzzi logo, useful to hold small items. Its functionality is guaranteed by the easy installation and removal from the vehicle handlebar.*



**COPRI SERBATOIO  
TANK COVER**

.....  
COD. 2S000038

Realizzato in Cordura con inserti in pelle, permette di montare la borsa serbatoio dedicata.

*Made of Cordura with leather inserts, allows mounting the dedicated tank bag.*



**PEDANE PILOTA  
PILOT FOOTRESTS**

.....  
COD. B064249

Pedane pilota reclinabili realizzate in alluminio ricavato dal pieno lucidate a specchio, mantengono la stessa ergonomia di guida di quelle di serie ma offrono un design alleggerito e personalizzato in linea con lo stile della moto.

*Reclining rider footpegs made of high-gloss polished billet aluminium, they maintain the same driving ergonomics like the standard ones, but offer a light-weight and customized design in line with the style of the motorcycle.*



**PEDANE PASSEGGERO  
PASSENGER FOOTRESTS**

.....  
COD. B064248

Realizzate in alluminio ricavato dal pieno lucidate a specchio. Mantengono lo stesso design delle pedane pilota. Regolabili orizzontalmente in quattro posizioni attraverso un meccanismo a molla che facilita il loro posizionamento ottimale.

*Made of high-gloss polished billet aluminium. Maintain the same design of the rider footpegs. Horizontally adjustable in four positions by means of the spring mechanism that facilitates their ideal positioning.*



**BORSA SERBATOIO  
TANKBAG**

.....  
COD. 2S000039

Borsa in Cordura con inserti in pelle, estensibile, dotata di pratiche tasche e di maniglia per il trasporto, si fissa al copri serbatoio tramite sganci rapidi e chiusura micrometrica. È dotata di cuffia anti-pioggia.

*Extensible Cordura bag with leather inserts, equipped with practical pockets and transport handle, applied to the tank cover by quick release clamps and micrometric closing. Includes rain cover.*



**PORTAPACCHI  
REAR RACK**

.....  
COD. B063992

Disegnato in tubo cromato dal Centro Stile Moto Guzzi, questo portapacchi amplia la capacità di carico della moto consentendo il montaggio dei bauli accessorio dedicati grazie alle apposite predisposizioni di fissaggio.

*Designed in chrome tube by Centro Stile Moto Guzzi, it expands the load capacity of the motorcycle, allowing to mount dedicated accessory cases thanks to the special fixing arrangements.*





**BAULETTO 50 lt CON CUSCINO  
50 LT TOP BOX**

.....  
COD. CM228501 NERO/BLACK  
COD. CM228502 BIANCO/WHITE

Baule da 50 lt. a sgancio rapido, può ospitare 2 caschi integrali. Guscio superiore verniciato in tinta veicolo, dotato di schienalino. Necessita di portapacchi B063992.

*50 litres box with quick release system, can hold 2 flip up helmets. Upper cover painted in the same colour as the vehicle, equipped with backrest. Requires luggage carrier B063992.*



**BAULE 65 lt CON CUSCINO  
65 LT TOP CASE**

.....  
COD. CM262801 NERO/BLACK  
COD. CM262802 BIANCO/WHITE

Baule in vetroresina da 65 lt, verniciato in tinta veicolo con serrature cromate. Il suo interno è rifinito in vellutino, ed è dotato di specchio, rete salvaggetti e pistone, che lo rendono funzionale, piacevole e distintivo. Necessita di portapacchi B063992.

*65 litre fibreglass top box, painted in the same colour as the vehicle, with chrome locks. Its interior is refinished with velvet and equipped with mirror, object holder net and piston that render it functional agreeable and distinctive. Requires luggage carrier B063992.*



**KIT SCARICHI OMOLOGATI  
HOMOLOGATED MUFFLERS SET**

.....  
COD. 2S000030

Per sentire il ruggito di una vera moto custom: questi scarichi slip on sono omologati e presentano uno stile simile agli scarichi di serie ma con una finitura dedicata e fondello specifico.

*To hear the roar of a true custom motorcycle: These slip on exhausts are approved and have a style similar to standard exhausts but with a dedicated finishing and specific back cover.*



**FONDELLI SCARICO  
EXHAUST ENDCUPS**

.....  
COD. B064289

Speciali fondelli da applicare allo scarico di serie per personalizzare lo stile del veicolo. L'involucro esterno è realizzato in acciaio inox lucidato a specchio mentre il terminale interno è realizzato in alluminio ricavato dal pieno con finitura lucida.

*Special end caps to be applied to the standard exhaust to personalize the style of the vehicle. The outer casing is made of high-gloss polished stainless steel while the internal end part is made of billet aluminium with polished finishing.*



**BORSE RIVESTITE IN PELLE  
LEATHER SIDE CASES**

.....  
COD. B064239

Disegnate dal Centro Stile Moto Guzzi, rivestite in pelle naturale da artigiani specializzati. Realizzate a mano, sposano la linea originale della moto offrendo una personalizzazione ricercata, utilizzando pellami italiani di pregio.

*Designed by the Moto Guzzi Style Centre, coated with natural leather by skilled artisans. Manually crafted, they match the original line of the motorcycle, offering a refined personalized aspect, using prestigious Italian leathers.*



**BORSE INTERNE PER VALIGIE  
LATERALI  
INNER BAGS FOR SIDE CASES**

.....  
COD. B064250

Costruite nella stessa forma delle valigie che le contengono, possono essere staccate e trasportate facilmente. Set realizzato con materiali altamente performanti e tecniche innovative che ne garantiscono impermeabilità e resistenza.

*Designed with the same shape of the cases containing them, they can be easily removed and carried. Set made of high-performance materials and innovative techniques guaranteeing water tightness and resistance.*



**PORTA TARGA  
PLATE SUPPORT**

.....  
COD. B064254  
COD. 2S000033 USA

Elegante portatarga omologato realizzato in acciaio inox con finiture lucide.

*Elegant approved plate holder made of stainless steel with glossy finishing.*



**ALLARME ELETTRONICO  
ELECTRONIC ALARM**

.....  
COD. 2D000027

Sistema di allarme compatto radiocomandato e autoalimentato di ultima generazione. Tra le sue specifiche offre: blocco motore, sensore di spostamento integrato, elevato livello di protezione.

*State of the art self-powered remote control compact alarm system. Its specifications include: engine block, built in motion sensor, high protection degree.*





**GUZZI MULTIMEDIA PLATFORM**  
**GUZZI MULTIMEDIA PLATFORM**

.....  
COD. 2S000157

GMP è il nuovo dispositivo che consente di collegare il proprio Smartphone alla moto, trasformandola in una vera e propria piattaforma multimediale. Per l'installazione utilizzare il supporto dedicato 2S000170.

*GMP is the new device that allows you to connect your smartphone to the motorcycle, turning it to a real multimedia platform. To mount it, use the dedicated bracket 2S000170.*



**KIT SUPPORTO CENTRALINA GMP**  
**GMP INSTALLATION KIT**

.....  
COD. 2S000156

Kit supporto dedicato al fissaggio del GMP, non necessita di cablaggi in quanto già predisposti nella moto.

*Dedicated bracket kit for fastening the GMP, does not require wiring harness since it is already provided on the motorcycle.*



**TELO COPRIMOTO TOURING**  
**CON BAULE**  
**TOURING BIKE COVER**  
**WITH TOP BOX**

.....  
COD. B064242

Telo su misura da interno per la protezione dalla polvere da utilizzare durante le soste in garage della moto. È realizzato in un tessuto elasticizzato bicolore con grafica dedicata.

*Tailor-made motorcycle cover for inside to protect against dust, intended for use during long periods of storing the bike in a garage. It is made from an elasticised bi-coloured fabric with dedicated graphics.*



**KIT SUPPORTO USB**  
**USB SOCKET KIT**

.....  
COD. 2S000315

Preso USB fornita di supporto dedicato per installazione nel sottosella, per la ricarica dei supporti elettronici, non consente il dialogo con gli apparati elettronici del mezzo.

*USB socket with bracket for installation under the saddle, to recharge the electronic media, does not allow dialogue with the electronic devices of the vehicle.*



**TELO COPRIMOTO TOURING**  
**TOURING BIKE COVER**

.....  
COD. B064241

Telo su misura da interno per la protezione dalla polvere da utilizzare durante le soste in garage della moto. È realizzato in un tessuto elasticizzato bicolore con grafica dedicata.

*Tailor-made motorcycle cover for inside to protect against dust, intended for use during long periods of storing the bike in a garage. It is made from an elasticised bi-coloured fabric with dedicated graphics.*







**CALIFORNIA**

**1400 CUSTOM**

  
**MOTO GUZZI®**





**PARABREZZA MEDIO  
SUPPORTI RIBASSATI  
MEDIUM WINDSHIELD  
LOWER BRACKETS**

.....  
COD. 2S000544

Parabrezza di misura media con la lastra in Lexan antiurto e antigraffio. Omologato secondo le normative DOT. Si monta facilmente grazie ai supporti ribassati da acquistare separatamente. H44 x L52 cm.

*Medium sized windshield with shockproof and scratch resistant Lexan sheet. Approved according to the DOT standards. It is easy to mount due to its lowered brackets, to be purchased separately. H44 x L52 cm.*



**KIT SUPPORTI PARABREZZA  
RIBASSATI  
WINDSHIELD LOWER BRACKETS KIT**

.....  
COD. 2S000542

Robusto kit di fissaggio, a misura ridotta, dotato di supporti specifici per il montaggio del parabrezza.

*Small sized solid fastening kit, equipped with specific brackets for mounting the windshield.*



**PARABREZZA SUPPORTI STANDARD  
WINDSHIELD STANDARD BRACKETS**

.....  
COD. 605854M

Parabrezza con la lastra in Lexan antiurto e antigraffio, che mantiene nel tempo inalterate le caratteristiche di trasparenza e lucentezza. Omologato secondo le normative DOT. Si monta facilmente grazie ai supporti standard da acquistare separatamente. H57 x L58 cm.

*Windshield with shockproof and scratch resistant Lexan sheet, maintaining the transparency and gloss characteristics unaltered over time. Approved according to the DOT standards. Can be easily mounted due to the standard brackets, to be purchased separately. H57 x L58 cm.*



**DEFLETTORI ARIA PARABREZZA  
WINDSHIELD AIR DEFLECTORS**

.....  
COD. B064235

Appendici da applicare nella zona sottostante al parabrezza per aumentare la protezione ed il comfort di guida offerti al pilota.

*Attachments to be applied under the windshield to increase rider's protection and driving comfort.*



**PARABREZZA SPORT  
SUPPORTI RIBASSATI  
SPORT WINDSHIELD  
LOWER BRACKETS**

.....  
COD. 2S000548

Parabrezza di misura particolarmente ridotta con la lastra in Lexan antiurto e antigraffio, che mantiene nel tempo inalterate le caratteristiche di trasparenza e lucentezza. Omologato secondo le normative DOT. Si monta facilmente grazie ai supporti ribassati da acquistare separatamente. H34 x L41 cm.

*Specially reduced sized windshield with shockproof and scratch resistant Lexan sheet, maintaining the transparency and gloss characteristics unaltered over time. Approved according to the DOT standards. It is easy to mount due to its lowered brackets, to be purchased separately. H34 x L41 cm.*



**PARABREZZA MEDIO  
SUPPORTI STANDARD  
MEDIUM WINDSCREEN  
STANDARD BRACKETS**

.....  
COD. 2S000546

Parabrezza di misura media con la lastra in Lexan antiurto e antigraffio, che mantiene nel tempo inalterate le caratteristiche di trasparenza e lucentezza. Omologato secondo le normative DOT. Si monta facilmente grazie ai supporti standard da acquistare separatamente. H44 x L52 cm.

*Medium sized windshield with shockproof and scratch resistant Lexan sheet, maintaining the transparency and gloss characteristics unaltered over time. Approved according to the DOT standards. Can be easily mounted due to the standard brackets, to be purchased separately. H44 x L52 cm.*



**PARABREZZA GRANDE  
SUPPORTI STANDARD  
WIDE WINDSCREEN  
STANDARD BRACKETS**

.....  
COD. 2S000547

Parabrezza di misura grande con la lastra in Lexan antiurto e antigraffio, che mantiene nel tempo inalterate le caratteristiche di trasparenza e lucentezza. Omologato secondo le normative DOT. Si monta facilmente grazie ai supporti standard da acquistare separatamente. H70 x L59 cm.

*Large sized windshield with shockproof and scratch resistant Lexan sheet, maintaining the transparency and gloss characteristics unaltered over time. Approved according to the DOT standards. Can be easily mounted due to the standard brackets, to be purchased separately. H70 x L59 cm.*



**KIT SUPPORTI PARABREZZA  
STANDARD  
WINDSCREEN STANDARD  
BRACKETS KIT**

.....  
COD. 605853M

Robusto kit di fissaggio, a misura standard, dotato di supporti specifici per il montaggio del parabrezza. Necessita delle minuterie 606255M.

*Standard size solid fastening kit, equipped with specific brackets for windshield mounting. Requires 606255M small metallic parts.*





**MINUTERIE PER SUPPORTI  
PARABREZZA STANDARD  
WINDSCREEN STANDARD  
BRACKETS SMALL METALLIC PARTS**

**COD. 606255M**

Minuterie necessarie pr il montaggio del kit supporti parabrezza standard 605853M.  
Small metallic parts required to mount the standard windshield brackets kit 605853M.



**CUPOLINO CUSTOM  
CUSTOM FLYSCREEN**

**COD. 2S000028**

Realizzato in Plazcryn antiurto, fumè, con serigrafia Moto Guzzi in grigio chiaro. I supporti sono verniciati a polvere di colore nero.  
Made of shock-proof Plazcryn, smoke tinted, with Moto Guzzi light grey screen printing. The brackets are powder painted in black.



**LEVA FRIZIONE  
CLUTCH LEVER**

**COD. B064256**

Speciale leva della frizione regolabile realizzata in alluminio, ricavata dal pieno con design personalizzato e con finitura antigraffio lucida.  
Special adjustable clutch lever made of billet aluminium, with custom design and glossy scratch resistant finishing.



**LEVA FRENO  
BRAKE LEVER**

**COD. B064255**

Speciale leva del freno regolabile realizzata in alluminio, ricavata dal pieno con design personalizzato e con finitura antigraffio lucida.  
Special adjustable brake lever made of billet aluminium, with custom design and glossy scratch resistant finishing.



**SPECCHIETTI RETROVISORI  
MIRRORS**

**COD. B064245**

Speciali specchietti retrovisori omologati realizzati in alluminio ricavati dal pieno con finitura antigraffio lucida.  
Special approved rear-view mirrors made of billet aluminium with glossy scratch resistant finishing.



**SPECCHIETTI RETROVISORI NERI  
BLACK MIRRORS**

**COD. 2S000031**

Speciali specchietti retrovisori omologati realizzati in alluminio ricavato dal pieno con finitura nera.  
Special approved rear-view mirrors made of billet aluminium with black finishing.



**KIT COPERCHIO POMPA FRENO  
E FRIZIONE  
BRAKE AND CLUTCH PUMP  
COVER KIT**

**COD. B064259**

Speciali coperchi delle pompe freno e frizione realizzati in alluminio ricavati dal pieno con finitura antigraffio lucida.  
Special covers for brake and clutch pumps made from billet aluminium with glossy scratch resistant finishing.



**MANOPOLE IN ALLUMINIO  
ALUMINIUM HANDGRIPS**

**COD. B064257**

Speciali manopole realizzate in alluminio ricavate dal pieno con inserti anti scivolo in gomma e finitura lucida.  
Special billet aluminium handlebars with rubber non-skid inserts and glossy finishing.





**MANOPOLE RISCALDATE  
HEATED HANDGRIPS**

.....  
COD. B064270

Per chi ama viaggiare a lungo in tutte le stagioni, facilmente installabili grazie alla predisposizione presente su tutte le California. Contribuiscono al comfort di guida, evitando che le mani possano indolenzirsi a causa del freddo.

*For those who love travelling in all seasons, easily mountable due to the arrangement on all California. They contribute to the driving comfort, preventing hand stiffening because of the cold.*



**SUPPORTO GPS  
GPS BRACKET**

.....  
COD. B064243

Supporto realizzato in acciaio inox lucido con predisposizione per il montaggio del navigatore satellitare.

*Bracket made of glossy stainless steel with arrangement for mounting the satellite navigator.*



**KIT LUCI SUPPLEMENTARI  
FOG LIGHTS KIT**

.....  
COD. B064251

I fari supplementari offrono una migliore visibilità durante la guida notturna e si integrano perfettamente con il look del veicolo grazie alle sue finiture cromate. I due fari vengono installati sotto gli indicatori di direzione tramite staffe appositamente studiate per non compromettere la guidabilità del mezzo.

*The additional headlamps offer better visibility during night driving, completing perfectly the look of the vehicle thanks to their chromed finishing. The two headlamps are mounted under the turn indicators with clamps specifically designed to avoid compromising the driving of the vehicle.*



**GUANCIALI SERBATOIO CROMATI  
CHROMED TANK COVERS**

.....  
COD. B064244

Le cover laterali del serbatoio cromate personalizzano lo stile della moto rendendola una vera «fuoriserie».

*The side tank covers, made of steel with chromed finish, customize the style of the motorcycle, making it a "custom-built" vehicle.*



**COVER SERBATOIO OLIO FRENO  
POSTERIORE  
BRAKE OIL TANK COVER**

.....  
COD. B064288

Realizzato in alluminio ricavato dal pieno, con una finitura lucida, personalizza il look del veicolo. Ricopre completamente il corpo del serbatoio olio freno lasciando inalterate le funzionalità. È di facile installazione.

*Made from billet aluminium, with a polished finish, it customizes the look of the vehicle. Covers completely the body of the brake oil tank, without altering the functions. Easy to mount.*



**COPRI STELI FORCELLA  
FORK SLEEVE COVERS**

.....  
COD. B064252

I copri steli forcella con finitura cromata si abbinano agli altri elementi in alluminio, già presenti sul veicolo, per esaltare le zone laterali.

*The fork sleeve covers with chrome finishing match the other aluminium elements, already mounted on the vehicle, to enhance the side areas.*



**SET BUSSOLE TESTATA IN  
ALLUMINIO  
ALUMINIUM HEAD BUSHINGS SET**

.....  
COD. 2S000348

Set di quattro distanziali in alluminio ricavato dal pieno, da montare in sostituzione delle viti che fissano le cover delle teste cilindro. Le viti a corredo sono in acciaio inox lucidato.

*Set of four aesthetic spacers made from billet aluminium, to be mounted in place of the screws that hold the cover of the cylinder head. The screws supplied with the kit are made of polished stainless steel.*



**COPRI INIETTORI  
INJECTOR COVERS**

.....  
COD. B064253

La coppia di copri iniettori realizzati in alluminio con finitura spazzolata sostituisce quella di serie, assicurando alla moto un look più ricco, più curato e coerente con le parti in alluminio già presenti.

*The injector covers made of aluminium with brushed finishing replaces the standard one, providing the motorcycle with a richer, refined and consistent look with the aluminium parts already mounted.*





**KIT PROTEZIONE TESTE  
CYLINDER COVERS PROTECTION KIT**

.....  
COD. B064247

Speciali protezioni laterali cilindri realizzate in alluminio ricavato dal pieno finite con la lucidatura a specchio. Si integrano perfettamente con lo stile ed il design della moto. Complete di supporti in acciaio inox lucidati a specchio.

*Special cylinder side shields made from billet aluminium, finished with high-gloss polishing. They perfectly match with style and design of the motorcycle. Provided with high-gloss polished stainless steel brackets.*



**KIT PARACALORE CILINDRI  
THERMAL PROTECTION SET**

.....  
COD. 2S000032

Ogni paracalore è realizzato in acciaio inox lucidato a specchio, con inserti in abs che migliorano il design ed attenuano il contatto delle ginocchia con il motore. Proteggono dal calore generato dal cilindro, per una guida più sicura e confortevole.

*Each heat shield is made from high-gloss polished stainless steel, with abs inserts improving design and reducing the contact of the knees with the engine. They protect from the heat generated by the cylinder, for a more secure and comfortable driving.*



**SELLA COMFORT CUSTOM  
CUSTOM COMFORT SADDLE**

.....  
COD. 2S000063

Comfort offerto a pilota grazie all'inserto in gel ricavato nelle zone di seduta. In colore nero. Dicitura «comfort gel» punzonata in rilievo. Stessa altezza della sella di serie.

*Comfort for the pilot due to the gel insert in the saddle. Black. "Comfort gel" text engraved in relief. Same height as the standard series.*



**SELLA COMFORT TOURING  
TOURING COMFORT SADDLE**

.....  
COD. B064236

Comfort offerto a pilota e passeggero grazie agli inserti in gel ricavati nelle zone di seduta. Materiale bicolore in linea con l'allestimento top della moto. Dicitura «comfort gel» punzonata in rilievo. Stessa altezza della sella di serie.

*Comfort for the driver and passenger thanks to the gel inserts in the saddle. Bi-coloured material in line with the top equipment of the motorcycle. "Comfort gel" text engraved in relief «comfort gel». Same height as the standard series.*



**PARAURTI ANTERIORE  
FRONT BUMPER**

.....  
COD. B063588

Disegnato in tubo cromato dal Centro Stile Moto Guzzi segue le linee del motore. Offre una protezione specifica al motore ed alle gambe del pilota.

*Designed by the Moto Guzzi Style Centre, this bumper of chromed tube follows the lines of the engine. It offers specific protection to the engine and driver's legs.*



**SELLA IN PELLE TOURING  
TOURING LEATHER SADDLE**

.....  
COD. B064237

Per chi ricerca una finitura di lusso che sposi lo stile pregiato offerto dalla moto è disponibile una sella rivestita in vera pelle da artigiani specializzati.

*For those looking for a luxurious finishing matching the valuable style of this vehicle, we offer a saddle made with in genuine leather by skilled artisans.*



**SELLA RIBASSATA COMFORT  
TOURING  
TOURING COMFORT LOWER SADDLE**

.....  
COD. B064238

Sella che unisce il comfort del gel alla comodità del profilo rivisto e ribassato per un migliore e più sicuro appoggio a terra. Lo stesso comfort è offerto al passeggero. Rifinita con materiale bicolore, arricchita con dicitura «comfort gel».

*Saddle that unites the comfort provided by gel and the convenience offered by the revised and lowered profile for a better and safer contact with the ground. The passenger benefits of the same comfort. Refinished with bi-coloured material, enriched with the text "comfort gel".*



**ROSETTE FORCELLONE  
SWINGARM WASHERS**

.....  
COD. B064272

Rosette speciali realizzate in alluminio ricavate dal pieno per personalizzare lo stile della tua California.

*Special washers made of billet aluminium to personalize the style of your California.*





**PEDANE PILOTA  
PILOT FOOTRESTS**

.....  
COD. B064249

Pedane pilota reclinabili realizzate in alluminio ricavato dal pieno lucidate a specchio, mantengono la stessa ergonomia di guida di quelle di serie ma offrono un design alleggerito e personalizzato in linea con lo stile della moto.

*Reclining rider footpegs made of high-gloss polished billet aluminium, they maintain the same driving ergonomics like the standard ones, but offer a light-weight and customized design in line with the style of the motorcycle.*



**PEDANE PASSEGGERO  
PASSENGER FOOTRESTS**

.....  
COD. B064248

Realizzate in alluminio ricavato dal pieno lucidate a specchio. Mantengono lo stesso design delle pedane pilota. Regolabili orizzontalmente in quattro posizioni attraverso un meccanismo a molla che facilita il loro posizionamento ottimale.

*Made of high-gloss polished billet aluminium. Maintain the same design of the rider footpegs. Horizontally adjustable in four positions by means of the spring mechanism that facilitates their ideal positioning.*



**BORSA SERBATOIO  
TANKBAG**

.....  
COD. 2S000039

Borsa in Cordura con inserti in pelle, estensibile, dotata di pratiche tasche e di maniglia per il trasporto, si fissa al copri serbatoio tramite sganci rapidi e chiusura micrometrica. È dotata di cuffia anti-pioggia.

*Extensible Cordura bag with leather inserts, equipped with practical pockets and transport handle, applied to the tank cover by quick release clamps and micrometric closing. Includes rain cover.*



**PORTAPACCHI  
REAR RACK**

.....  
COD. B063992

Disegnato in tubo cromato dal Centro Stile Moto Guzzi, questo portapacchi amplia la capacità di carico della moto consentendo il montaggio dei bauli accessorio dedicati grazie alle apposite predisposizioni di fissaggio.

*Designed in chrome tube by Centro Stile Moto Guzzi, it expands the load capacity of the motorcycle, allowing to mount dedicated accessory cases thanks to the special fixing arrangements.*



**BORSA MANUBRIO  
HANDLEBAR BAG**

.....  
COD. 2S000034

Elegante e funzionale borsa-manubrio realizzata in cordura e pelle naturale che incornicia il marchio Moto Guzzi, utile per contenere piccoli oggetti. La sua funzionalità è garantita dalla facile installazione e rimozione dal manubrio del veicolo.

*Elegant and functional handlebar bag made of Cordura and natural leather with Moto Guzzi logo, useful to hold small items. Its functionality is guaranteed by the easy installation and removal from the vehicle handlebar.*



**COPRI SERBATOIO  
TANK COVER**

.....  
COD. 2S000038

Realizzato in Cordura con inserti in pelle, permette di montare la borsa serbatoio dedicata.

*Made of Cordura with leather inserts, allows mounting the dedicated tank bag.*



**BAULETTO 50 lt CON CUSCINO  
50 LT TOP BOX**

.....  
COD. CM228501 NERO/BLACK  
COD. CM228503 GRIGIO/GREY

Baule da 50 lt. a sgancio rapido, può ospitare 2 caschi integrali. Guscio superiore verniciato in tinta veicolo, dotato di schienalino. Necessita di portapacchi B063992.

*50 litres box with quick release system, can hold 2 flip up helmets. Upper cover painted in the same colour as the vehicle, equipped with backrest. Requires luggage carrier B063992.*



**BAULE NERO 65 LT CON CUSCINO  
65 LT BLACK TOP CASE**

.....  
COD. CM262801

Baule in vetroresina da 65 lt, verniciato in tinta veicolo con serrature cromate. Dispone di un ampio e confortevole cuscino poggia schiena per il passeggero. Il suo interno è rifinito in vellutino, ed è dotato di specchio, rete salvaoggetti e pistone, che lo rendono funzionale, piacevole e distintivo. Necessita di portapacchi B063992.

*65 litre fibreglass top box, painted in the same colour as the vehicle, with chrome locks. It has a large and comfortable backrest cushion for the passenger. Its interior is refinished with velvet and equipped with mirror, object holder net and piston that render it functional agreeable and distinctive. Requires luggage carrier B063992.*





**VALIGIE  
SIDE CASES**

.....  
COD. CM228701 NERO/BLACK  
COD. CM228703 GRIGIO/GREY

Coppia valigie rigide in tinta con il veicolo.  
Inclusive di kit supporti B064286

*Rigid cases set in colour matching vehicle.  
With support kit B064286*



**BORSE RIVESTITE IN PELLE  
LEATHER SIDE CASES**

.....  
COD. B064239

Disegnate dal Centro Stile Moto Guzzi, rivestite in pelle naturale da artigiani specializzati. Realizzate a mano, sposano la linea originale della moto offrendo una personalizzazione ricercata, utilizzando pellami italiani di pregio.

*Designed by the Moto Guzzi Style Centre, coated with natural leather by skilled artisans. Manually crafted, they match the original line of the motorcycle, offering a refined personalized aspect, using prestigious Italian leathers.*



**SUPPORTI VALIGIE  
SIDE CASES SUPPORT**

.....  
COD. B064286

Kit che permette di montare le valigie rigide laterali su California Custom, realizzato in materiale ad alta resistenza e trattato contro la corrosione e l'usura del tempo.

*Kit allowing to mount the rigid side cases on California Custom, made of high-strength material and treated against corrosion and weather's agents.*



**KIT SCARICHI OMOLOGATI  
HOMOLOGATED MUFFLERS SET**

.....  
COD. 2S000030

Per sentire il ruggito di una vera moto custom: questi scarichi slip on sono omologati e presentano uno stile simile agli scarichi di serie ma con una finitura dedicata e fondello specifico.

*To hear the roar of a true custom motorcycle: These slip on exhausts are approved and have a style similar to standard exhausts but with a dedicated finishing and specific back cover.*



**BORSE INTERNE PER VALIGIE  
LATERALI  
INNER BAGS FOR SIDE CASES**

.....  
COD. B064250

Costruite nella stessa forma delle valigie che le contengono, possono essere staccate e trasportate facilmente.

Set realizzato con materiali altamente performanti e tecniche innovative che ne garantiscono impermeabilità e resistenza.

*Designed with the same shape of the cases containing them, they can be easily removed and carried. Set made of high-performance materials and innovative techniques guaranteeing water tightness and resistance.*



**PARAURTI BORSE  
SIDE BAGS BUMPERS**

.....  
COD. B063624

Disegnato in tubo cromato dal Centro Stile Moto Guzzi segue le linee della moto. Offre una protezione specifica alle valigie montate sul veicolo.

*designed by Centro Stile moto Guzzi, this bumper, in chromed tube, follows perfectly the line of this motorcycle. Made to offer specific protection to the cases mounted on the vehicle.*



**FONDELLI SCARICO  
EXHAUST ENDCUPS**

.....  
COD. B064289

Speciali fondelli da applicare allo scarico di serie per personalizzare lo stile del veicolo. L'involucro esterno è realizzato in acciaio inox lucidato a specchio mentre il terminale interno è realizzato in alluminio ricavato dal pieno con finitura lucida.

*Special end caps to be applied to the standard exhaust to personalize the style of the vehicle. The outer casing is made of high-gloss polished stainless steel while the internal end part is made of billet aluminium with polished finishing.*



**PORTA TARGA  
PLATE SUPPORT**

.....  
COD. B064254  
COD. 2S000033 USA

Elegante portatarga omologato realizzato in acciaio inox con finiture lucide.

*Elegant approved plate holder made of stainless steel with glossy finishing.*





**ALLARME ELETTRONICO  
ELECTRONIC ALARM**

.....  
COD. 2D000027

Sistema di allarme compatto radiocomandato e autoalimentato di ultima generazione. Tra le sue specifiche offre: blocco motore, sensore di spostamento integrato, elevato livello di protezione.

*State of the art self-powered remote control compact alarm system. Its specifications include: engine block, built in motion sensor, high protection degree.*



**GUZZI MULTIMEDIA PLATFORM  
GUZZI MULTIMEDIA PLATFORM**

.....  
COD. 2S000157  
COD. 2S000156 KIT SUPPORTO/INSTALLATION KIT

GMP è il nuovo dispositivo che consente di collegare il proprio Smartphone alla moto, trasformandola in una vera e propria piattaforma multimediale. Per l'installazione utilizzare il supporto dedicato 2S000170.

*GMP is the new device that allows you to connect your smartphone to the motorcycle, turning it to a real multimedia platform. To mount it, use the dedicated bracket 2S000170.*



**KIT SUPPORTO USB  
USB SOCKET KIT**

.....  
COD. 2S000315

Presse USB fornita di supporto dedicato per installazione nel sottosella, per la ricarica dei supporti elettronici, non consente il dialogo con gli apparati elettronici del mezzo.

*USB socket with bracket for installation under the saddle, to recharge the electronic media, does not allow dialogue with the electronic devices of the vehicle.*



**TELO COPRIMOTO CUSTOM  
CUSTOM BIKE COVER**

.....  
COD. 2S000062

Telo su misura da interno per la protezione dalla polvere da utilizzare durante le soste in garage della moto. È realizzato in un tessuto elasticizzato bicolore con grafica dedicata.

*Tailor-made motorcycle cover for inside to protect against dust, intended for use during long periods of storing the bike in a garage. It is made from an elasticised bi-coloured fabric with dedicated graphics.*





MOTO GUZZI

PRESENTAZIONE MOTORI

# GRISO

1200 8V SE



  
MOTO GUZZI®





**CUPOLINO  
FLYSCREEN**

.....  
COD. GU06977200

Il cupolino in plexiglass rende Griso ancora più affascinante e migliora la penetrazione aerodinamica. Grazie alla sua qualità costruttiva, che impiega i migliori materiali, ha facilmente superato i severi test TÜV e DOT.

*The plexiglass top flyscreen makes Griso even more fascinating and improves the aerodynamic penetration. Thanks to the best material used and the quality of the construction process, this windshield passes the most severe TÜV and DOT tests.*



**ZAINO SERBATOIO GRANDE  
BIG TANKBAG**

.....  
COD. GU06481500

La borsa da serbatoio in Nylon e PVC ha un volume di circa 18 litri, ha cerniere antiacqua, inserti riflettenti e una cuffia anti-pioggia per assicurare la protezione dall'acqua. La sua maniglia anatomica permette di sganciarla dalla moto e trasportarla comodamente.

*The Nylon and PVC tank bag has a volume of approximately 18 litres, has waterproof zippers, reflective inserts and a rain proof cover to guarantee protection against water. Thanks to its anatomic handle can be detached from the motorcycle and comfortably transported.*



**BORSA PORTAPACCHI  
SPORT TAILBAG**

.....  
COD. GU973243500001

La borsa in Nylon e PVC con protezione anti-pioggia si fissa al portapacchi in modo pratico e sicuro e si asporta facilmente, diventando una comoda borsa a tracolla. Volume variabile da 8 a 12 litri.

*Nylon & PVC rainproof bag, easily & safely fastened to the luggage carrier and easily detachable, becoming a convenient carrying bag. Variable volume from 8 to 12 litres.*



**BORSA SELLA  
TOURING TAILBAG**

.....  
COD. 983033

La borsa sella, in Nylon e Pvc, offre grande capacità di carico con un volume variabile da 15 a 20 litri circa. Si fissa tramite quattro cinghie regolabili ai noddini posti sotto il codone. Una volta asportata, si trasporta comodamente con la pratica maniglia anatomica.

*The Nylon and Pvc saddle bag offers high load capacity with a variable volume from 15 to approximately 20 litres. It attaches through four adjustable straps to the latches under the tail fairing. Once removed, it can be easily carried using the practical anatomic handle.*



**ZAINO SERBATOIO PICCOLO  
SMALL TANKBAG**

.....  
COD. GU06481501

Pratica borsa da serbatoio in Nylon e PVC ha un volume ridotto che la rende poco ingombrante e facile da trasportare. La borsa ha cerniere antiacqua, inserti riflettenti e una cuffia anti-pioggia. La sua maniglia anatomica permette di sganciarla dalla moto e trasportarla comodamente.

*Practical Nylon and PVC tank bag with reduced volume, making it space-saving and easy to transport. The bag has waterproof zippers, reflective inserts and a rain proof cover. Thanks to its anatomic handle can be detached from the motorcycle and comfortably transported.*



**PORTAPACCHI  
REAR RACK**

.....  
COD. GU06677200

Il versatile e robusto portapacchi in acciaio verniciato a polvere, è stato disegnato appositamente per Griso e permette di fissare la borsa bauletto in tessuto dedicata.

*The versatile and robust luggage carrier made of powder painted stainless steel was specially designed for Griso and allows fastening the dedicated fabric top box bag.*



**KIT BORSE SEMIRIGIDE  
SEMRIGID PANNIERS KIT**

.....  
COD. GU06480100

Il kit è composto da una coppia di borse semirigide in tessuto, facilmente rimovibili, grazie al sistema brevettato fast-click® con chiave, dai supporti studiati, testati ed omologati dal reparto tecnico Moto Guzzi, e dalla cuffia anti-pioggia. Volume variabile da 18 a 20 litri.

*The kit is composed of a pair of easily removable fabric semi-rigid bags thanks to the patented fast-click® system with key, fitted with brackets designed, tested and approved by the Moto Guzzi technical department, and with a rainproof cover. Variable volume from 18 to 20 litres.*



**SCARICO OMOLOGATO  
EXHAUST KIT**

.....  
COD. 983181

Questo scarico, realizzato in collaborazione con Termignoni, è caratterizzato dalla forma conica e dal fondello ricavato dal pieno. Realizzato in acciaio inox lucidato e omologato ai sensi della normativa euro3 con catalizzatore, garantisce un incremento delle prestazioni e una sonorità entusiasmante.

*This exhaust, made in collaboration with Termignoni, has a conical size and a billet end cap. Made of polished stainless steel and approved according to euro3 standard with catalyst, it guarantees increase in performance and fascinating sound.*





**CAVALLETTO MANUTENZIONE  
SERVICE STAND**

.....  
COD. GU973243500010

Il cavalletto di servizio, realizzato in acciaio verniciato a polvere, unitamente al supporto anteriore in dotazione, permette di sollevare facilmente la moto per eseguire la manutenzione ordinaria o, in caso di fermo prolungato, di spostarla agevolmente grazie alle robuste ruote in nylon.  
*The service stand, made of powder painted stainless steel, together with the supplied front support, allows to easily lift the motorcycle to perform ordinary maintenance operations or during long stops, to easily move it thanks to its robust nylon wheels.*



**TELO COPRIMOTO  
BIKE COVER**

.....  
COD. GU973243500000

Telo coprimoto nero, con logo Griso argento sui due lati, realizzato in tessuto antigraffio.  
*Black motorcycle cover with silver Griso logo on the sides, made in scratch-proof fabric.*







STELVIO

1200 8V

  
MOTO GUZZI®





### PARABREZZA MAGGIORATO WIDE WINDSHIELD KIT

.....  
COD. 887289

Parabrezza di dimensioni maggiorate (omologato DOT) è studiato per offrire la massima protezione aerodinamica. È stato testato su strada in ogni condizione dai collaudatori Moto Guzzi.

*The enhanced size windshield (DOT approved) is designed to offer the maximum aerodynamic protection. It is road tested under all conditions by Moto Guzzi testers.*



### KIT INSTALLAZIONE NAVIGATORE NAVIGATOR INSTALLATION KIT

.....  
COD. 983151

Il supporto specifico per il montaggio del navigatore è realizzato in alluminio fresato dal pieno e viene fornito completo di viti specifiche. L'impianto elettrico della moto è già predisposto per il montaggio con un connettore di alimentazione dedicato.

*The specific support for mounting the navigator is made of billet milled aluminium and is supplied with the specific screws. The electrical system of the motorcycle is already set up for mounting a dedicated power supply connector.*



### PARAMANI HANDGUARDS

.....  
COD. 983157

Kit composto dalla coppia di paramani in materiale plastico, terminali manubrio dedicati (è possibile abbinarli alle manopole riscaldate cod. 983155), contrappesi dedicati e bulloneria necessaria per il montaggio.

*This kit includes a pair of plastic handguards, handlebar ends (compatible with heated grips cod. 983155), dedicated counterweights and small metallic parts for mounting.*



### PARACOPPA BELLYPAN KIT

.....  
COD. 883979

Il paracoppa in alluminio è realizzato utilizzando una lega ad alta resistenza da 3mm di spessore, per proteggere da urti o pietrisco sollevato dalla ruota anteriore, oltre ad un efficace raffreddamento del motore. Si può montare anche in presenza del paramotore.

*The aluminium crankcase guard is made using a 3 mm thick high resistance alloy, to protect against impact and dirty from front wheel, beside an efficient cooling of the engine. It can also be installed in combination with the engine cover.*



### KIT DEFLETTORI DEFLECTORS KIT

.....  
COD. 887290

Elementi accessori per aumentare la protezione del pilota in ogni condizione di guida.

*Accessory elements to increase the driver's protection in any driving conditions.*



### MANOPOLE RISCALDATE HEATED HANDGRIPS

.....  
COD. 983155

Il kit è composto dalla coppia di manopole riscaldate completo di cablaggi dedicati. L'attivazione avviene tramite il menù strumentazione, selezionando con il cursore l'apposita voce e regolando la temperatura tra le 3 disponibili. L'impianto elettrico della moto è già predisposto per il montaggio. Possono essere montate anche in presenza dei paramani.

*This kit is composed by two heated handlebar grips equipped with dedicated connection cables. The activation takes place through the tools menu, selecting with the cursor the specific item and adjusting the temperature among the 3 available ones. The electrical system of the motorcycle is already set up for mounting. They can be mounted even if there are hand guards.*



### PROTEZIONE CARDANO FINAL DRIVE GUARD

.....  
COD. 983173

La protezione cardano è realizzata in acciaio trattato e verniciato, e protegge la trasmissione da urti accidentali.

*The cardan shaft guard is made of treated and painted stainless steel, protecting the transmission against accidental impacts.*



### PARAMOTORE ENGINE GUARD

.....  
COD. 887322

Il paramotore dedicato è realizzato in acciaio trattato e verniciato e garantisce una efficace protezione del motore in caso di caduta a bassa velocità. È inoltre predisposto per il montaggio, opzionale, del supporto luci supplementari e del paracoppa in alluminio.

*The dedicated engine guard is made in treated and painted steel and guarantees efficient protection of the engine in case of crash at low speed. It's also compatible with additional light brackets and aluminium crankcase guard.*





**KIT LUCI SUPPLEMENTARI  
FOG LIGHTS KIT**

.....  
COD. 887321

Fari fendinebbia realizzati in lega di magnesio e alluminio, con potenza totale di 110W. Comandabili tramite l'apposito pulsante. L'impianto elettrico della moto e la strumentazione sono già predisposti per il montaggio. Le luci supplementari si montano sul paramotore (cod. 887322).

*Fog lamps approved made of magnesium and aluminium alloy, providing a total power of 110W. They can be operated through the appropriate button. The electric system of the motorcycle and the instruments are already designed for mounting. The supplementary lights are mounted on the engine cover (code 887322).*



**BAULETTO IN ALLUMINIO  
ALUMINIUM TOP CASE**

.....  
COD. B063103

Bauletto in alluminio della capacità di 38 litri, con piastra specifica di interfaccia tra il portapacchi e il bauletto che determina una posizione dello stesso più confortevole per il passeggero.

*Aluminium top box with a 38 litre capacity, with specific interface between luggage carrier and top box. This combination gives the passenger the best riding comfort possible.*



**MANIGLIE PER VALIGIE IN ALLUMINIO  
HANDLE KIT FOR ALUMINIUM  
SIDE CASES**

.....  
COD. 896055

La coppia di maniglie in nylon si fissa tramite velcro ai supporti in alluminio presenti sui coperchi valigia, e permette di asportare e trasportare facilmente e comodamente le valigie.

*The nylon handle pair is fastened with velcro to the aluminium brackets on the case covers, allowing to easily remove and conveniently transport cases.*



**VALIGIE IN ALLUMINIO  
ALUMINIUM SIDE CASES**

.....  
COD. B064004

Il kit è composto da una coppia di valigie in alluminio nero anodizzato con una capacità di 37 litri ciascuna. Il kit serrature permette di assicurare le borse al veicolo nonché ovviamente di garantire la loro chiusura. Possono essere equipaggiate inoltre con pratiche borse interne in nylon cod. 983303.

*The kit includes a pair of black anodized aluminium cases, 37 litres capacity each. The lock kits allows to mount the cases on the vehicle and naturally also to close them. They can also be equipped with practical internal nylon bag, code 983303.*



**BAULETTO GOFFRATO  
BLACK EMBOSSED TOP BOX**

.....  
COD. GU05487631

Bauletto rigido, grazie al volume di 45 litri, può contenere due caschi integrali. Lo schienalino in skay aumenta il comfort del passeggero, la piastra supporto in materiale composito completa il kit e ne facilita il montaggio. L'apertura a scatto lo rende pratico e di facile accesso.

*Rigid top box which can contain two flip up helmet thanks to its 45 litre volume. The skay backrest increases the passenger's comfort, the composite material support plate completes the kit and facilitates the mounting. The snap-on opening makes it practical and easy to access.*



**BAULETTO  
TOP BOX**

.....  
COD. CM226701 NERO/BLACK  
COD. CM226702 BIANCO/WHITE  
COD. CM226711 ARANCIO RAME/ORANGE  
COD. CM226713 BLU/BLUE

Kit bauletto 48 lt. verniciato nel colore del veicolo, con schienalino del colore/materiale della sella. Può contenere 2 caschi.

*48 litre top box kit, painted with the same colour of the vehicle, with backrest having the same colour/material as the saddle. Can contain two helmets.*



**BORSE INTERNE VALIGIE ALLUMINIO  
INNER BAGS KIT FOR ALUMINIUM  
SIDE CASES**

.....  
COD. 983303

Coppia di borse in nylon per valigie in alluminio, dotate di maniglia superiore.

*Pair of nylon bags for aluminium cases, equipped with upper handle.*



**BORSE LATERALI  
SIDE PANNIERS**

.....  
COD. 983148Y02 NERO/BLACK  
COD. 983148BM BIANCO/WHITE  
COD. 983148YA2 ARANCIO RAME/ORANGE  
COD. 98314800DE BLU/BLUE

Il kit borse è caratterizzato dalla verniciatura in tinta carrozzeria e dal volume totale di 60 litri. Il sistema di aggancio alla moto è stato studiato in modo da integrarsi perfettamente nella linea del codino.

*These side bags are painted to perfectly match the color of the vehicle and have a total volume of 60 litres. The fastening system has been designed to perfectly integrate the bags in the tail profile.*





**ALLARME ELETTRONICO  
ELECTRONIC ALARM**

.....  
COD. 2D000027

Antifurto elettronico inerziale secondo i più severi standard, in collaborazione con il leader di mercato Metasystem. Grazie alla predisposizione dell'impianto elettrico, è sufficiente connettere la centrale d'allarme all'apposito connettore e fissare la centrale al supporto dedicato.

*Inertial anti-theft system according to the highest standards, in collaboration with the market leader, Metasystem. Thanks to the electrical system arrangement, you just need to connect the alarm control unit to the appropriate connector and fix the control unit on the dedicated support.*



**TELO COPRIMOTO  
BIKE COVER**

.....  
COD. 983174

Telo coprimoto realizzato in tessuto nero antigraffio con logo Stelvio su entrambi i lati.

*Motorcycle cover made in scratch proof material with the Stelvio logo on both sides.*





# STELVIO

1200 8V NTX



  
MOTO GUZZI®





### KIT INSTALLAZIONE NAVIGATORE NAVIGATOR INSTALLATION KIT

.....  
COD. 983151

Il supporto specifico per il montaggio del navigatore è realizzato in alluminio fresato dal pieno e viene fornito completo di viti specifiche. L'impianto elettrico della moto è già predisposto per il montaggio con un connettore di alimentazione dedicato.

*The specific support for mounting the navigator is made of billet milled aluminium and is supplied with the specific screws. The electrical system of the motorcycle is already set up for mounting a dedicated power supply connector.*



### MANOPOLE RISCALDATE HEATED HANDGRIPS

.....  
COD. 983155

Il kit è composto dalla coppia di manopole riscaldate completo di cablaggi dedicati. L'attivazione avviene tramite il menù strumentazione regolando la temperatura tra le 3 disponibili. L'impianto elettrico della moto è già predisposto per il montaggio. Possono essere montate anche in presenza dei paramani.

*This kit is composed by two heated handlebar grips equipped with dedicated connection cables. The activation takes place through the tools menu adjusting the temperature among the 3 available ones. The electrical system of the motorcycle is already set up for mounting. They can be mounted even if there are hand guards.*



### BAULETTO GOFFRATO BLACK EMBOSSED TOP BOX

.....  
COD. GU05487631

Bauletto rigido, grazie al volume di 45 litri, può contenere due caschi integrali. Lo schienalino in skay aumenta il comfort del passeggero, la piastra supporto in materiale composito completa il kit e ne facilita il montaggio. L'apertura a scatto lo rende pratico e di facile accesso.

*Rigid top box which can contain two flip up helmet thanks to its 45 litre volume. The skay backrest increases the passenger's comfort, the composite material support plate completes the kit and facilitates mounting. The snap-on opening makes it practical and easy to access.*



### MANIGLIE PER VALIGIE IN ALLUMINIO HANDLE KIT FOR ALUMINIUM SIDE CASES

.....  
COD. 897774

La coppia di maniglie in nylon si fissa tramite velcro ai supporti in alluminio presenti sui coperchi valigia, e permette di asportare e trasportare facilmente e comodamente le valigie.

*The nylon handle pair is fastened with velcro to the aluminium brackets on the case covers, allowing to easily remove and conveniently transport cases.*



### PROTEZIONE CARDANO FINAL DRIVE GUARD

.....  
COD. 983173

La protezione cardano è realizzata in acciaio trattato e verniciato, e protegge la trasmissione da urti accidentali.

*The cardan shaft guard is made of treated and painted stainless steel, protecting the transmission against accidental impacts.*



### BAULETTO IN ALLUMINIO ALUMINIUM TOP CASE

.....  
COD. B063103

Bauletto in alluminio della capacità di 38 litri, con piastra specifica di interfaccia tra il portapacchi e il bauletto che determina una posizione dello stesso più confortevole per il passeggero.

*Aluminium top box with a 38 litre capacity, with specific interface between luggage carrier and top box. This combination gives the passenger the best riding comfort possible.*



### BORSE INTERNE PER VALIGIE IN ALLUMINIO INNER BAG S KIT FOR ALUMINIUM SIDE CASES

.....  
COD. 983303

Coppia di borse in nylon per valigie in alluminio, dotate di maniglia superiore.

*Pair of nylon bags for aluminium cases, equipped with upper handle.*



### ALLARME ELETTRONICO ELECTRONIC ALARM

.....  
COD. 2D000027

Antifurto elettronico inerziale secondo i più severi standard, in collaborazione con il leader di mercato Metasystem. Grazie alla predisposizione dell'impianto elettrico, è sufficiente connettere la centrale d'allarme all'apposito connettore e fissare la centrale al supporto dedicato.

*Inertial anti-theft system according to the highest standards, in collaboration with the market leader, Metasystem. Thanks to the electrical system arrangement, it is enough to connect the alarm control unit to the appropriate connector and fix the control unit on the dedicated support.*





**TELO COPRIMOTO  
BIKE COVER**

.....  
COD. 983174

Telo coprimoto realizzato in tessuto nero antigraffio con logo Stelvio su entrambi i lati.

*Motorcycle cover made in scratch proof material with the Stelvio logo on both sides.*







  
**MOTO GUZZI®**

— **APPAREL** —



**CASCHI  
HELMETS**

La grande tradizione motociclistica, la cura nei dettagli e l'utilizzo di materiali ricercati dalla elevata qualità si sintetizza nella nuova linea di caschi Moto Guzzi. Caschi progettati per garantire il massimo livello di protezione ed una ricercata cura del design per offrire dei modelli dalla forte personalità. Grande attenzione anche all'utilizzo di grafiche dal forte contenuto emozionale in grado di enfatizzare la Storia e l'heritage di Moto Guzzi (dal tricolore, alle grafiche racing tipiche degli anni '30).

*The great motorcycling tradition, the attention to detail and use of high quality materials are present in the new range of Moto Guzzi helmets. They have been designed to ensure the highest level of protection and design in order to provide objects with a strong personality. It has been set great attention to the use of graphics with strong emotional content, they emphasize the history and heritage of Moto Guzzi (the three-tone flag, the typical of the '30s racing graphics).  
US customers are advised to ask the local dealer for DOT helmets part numbers.*

**RACING 29  
CASCHI / HELMETS**

Calotta fibra di vetro, qualità nei dettagli e nelle finiture.  
Visiera parasole corta a scomparsa, cinturino con chiusura micrometrica.  
Interni estraibili traspiranti e lavabili.  
Made in Italy.  
Omologazione ECE 22.05.  
*Fiberglass shell, high quality and accurate details. Retractable Sun Visor.  
Micrometric retention system. Washable, removable and breathable Linninig  
Made in Italy.  
ECE 22.05. omologation*

**CROMO/CHROME  
.....**

<b>XS</b>	606069M01RC
<b>S</b>	606069M02RC
<b>M</b>	606069M03RC
<b>L</b>	606069M04RC
<b>XL</b>	606069M05RC

**ROSSO/RED  
.....**

<b>XS</b>	606070M01RR
<b>S</b>	606070M02RR
<b>M</b>	606070M03RR
<b>L</b>	606070M04RR
<b>XL</b>	606070M05RR

**MATT BLACK  
CASCHI / HELMETS**

Calotta fibra di vetro, qualità nei dettagli e nelle finiture.  
Visiera parasole corta a scomparsa, cinturino con chiusura micrometrica. Interni estraibili traspiranti e lavabili.  
Made in Italy.  
Omologazione ECE 22.05.

*Fiberglass shell, high quality and accurate details . Retractable Sun Visor.  
Micrometric retention system. Washable, removable and breathable Linninig  
Made in Italy.  
ECE 22.05. omologation*

**NERO/BLACK  
.....**

<b>XS</b>	606071M01B
<b>S</b>	606071M02B
<b>M</b>	606071M03B
<b>L</b>	606071M04B
<b>XL</b>	606071M05B

**ITALIAN PRIDE  
CASCHI / HELMETS**

Calotta fibra di vetro, qualità nei dettagli e nelle finiture.  
Visiera parasole corta a scomparsa, cinturino con chiusura micrometrica.  
Interni estraibili traspiranti e lavabili.  
Made in Italy.  
Omologazione ECE 22.05.

*Fiberglass shell, high quality and accurate details . Retractable Sun Visor.  
Micrometric retention system. Washable, removable and breathable Linninig  
Made in Italy.  
ECE 22.05. omologation*

**ARGENTO/SILVER  
.....**

<b>XS</b>	606073M01IP
<b>S</b>	606073M02IP
<b>M</b>	606073M03IP
<b>L</b>	606073M04IP
<b>XL</b>	606073M05IP



**STRIPES**  
CASCHI / HELMETS



Calotta fibra di vetro, qualità nei dettagli e nelle finiture.  
Visiera parasole corta a scomparsa, cinturino con chiusura micrometrica.  
Interni estraibili traspiranti e lavabili.  
Made in Italy.  
Omologazione ECE 22.05.

*Fiberglass shell, high quality and accurate details . Retractable Sun Visor. Micrometric retention system Washable, removable and breathable Linninig  
Made in Italy.  
ECE 22.05. omologation*



**BIANCO/WHITE**

XS	606074M01WS
S	606074M02WS
M	606074M03WS
L	606074M04WS
XL	606074M05WS



**NERO/BLACK**

XS	606072M01BS
S	606072M02BS
M	606072M03BS
L	606072M04BS
XL	606072M05BS

**JET SCRATCH**  
CASCHI / HELMETS



Calotta Jet in ABS.  
Colore cromo graffiato acciaio.  
Made in Italy.  
Bordatura in ecopelle cucita direttamente sulla calotta.  
Rivestimento interno in tessuto anallergico.  
Omologazione ECE 22.05.

*ABS Shell  
Chrome Scratch colour.  
Made in Italy.  
Ecoleather bordering directly sewed onto the shell.  
Internal antibacterial lining  
ECE 22.05 omologation*



**CROMO/CHROME**

S	606219M02S
M	606219M03S
L	606219M04S
XL	606219M05S



**GIACCA PELLE  
LEATHER JACKET**

Le nuove giacche in pelle Moto Guzzi sono state disegnate specificatamente sia per uomo che per donna. Sono giacche tecniche per l'utilizzo in moto, quindi sono presenti gli appositi alloggiamenti per le protezioni omologate CE spalle e gomiti (incluse) e quella per la protezione schiena, che sceglie il cliente. Sono confezionate con pellami bovini di alta qualità e sono le più leggere e morbide sul mercato. Hanno subito un trattamento estetico che le rende "usate", subito perfettamente vestibili e comodissime. Queste giacche, offrono imbottiture esterne sia estetiche che funzionali su spalle e gomiti, hanno cerniere di regolazione ai fianchi, 4 tasche esterne e inserti rifrangenti 3M. Contengono anche un gilet asportabile imbottito, trapuntato, anche questo con tasca. Sia le giacche uomo che donna, sono previste in 4 colori: nero, blu, cielo, rosso e nelle seguenti taglie: S-2XL uomo ; S-XL donna.

*New Guzzi's leather jackets are designed and engineered specifically for man and woman. It's a range of technical apparel for motorcycle use, so these jackets are equipped with pockets for shoulders and elbows protectors (CE protectors included) and backprotector (optional, to be selected by the user). The deep leather treatment gives to these jackets a genuine used look, easy fitting and makes these jackets very comfortable. Outside, we find aesthetical and functional quilting on shoulders and elbows, adjusting zipper, 4 external pockets, reflecting 3m scotchlite inserts. Inside the jacket you can find a remouvable quilted thermal vest. Both, men's and women's models are made in 4 colours: black, navy, sky, red. Men sizes S - 2XL Women sizes S - XL.*

**ROSSO/RED**  
.....  
UOMO / MAN

S	606092M00R
M	606092M01R
L	606092M02R
XL	606092M03R
XXL	606092M04R

**NERO/BLACK**  
.....  
UOMO / MAN

S	606092M00N
M	606092M01N
L	606092M02N
XL	606092M03N
XXL	606092M04N

**BLU/BLUE**  
.....  
UOMO / MAN

S	606092M00B
M	606092M01B
L	606092M02B
XL	606092M03B
XXL	606092M04B

**AZZURRO SKY/SKY BLUE**  
.....  
UOMO / MAN

S	606092M00A
M	606092M01A
L	606092M02A
XL	606092M03A
XXL	606092M04A

**ROSSO/RED**  
.....  
DONNA / WOMAN

S	606093M00R
M	606093M01R
L	606093M02R
XL	606093M03R

**NERO/BLACK**  
.....  
DONNA / WOMAN

S	606093M00N
M	606093M01N
L	606093M02N
XL	606093M03N

**BLU/BLUE**  
.....  
DONNA / WOMAN

S	606093M00B
M	606093M01B
L	606093M02B
XL	606093M03B

**AZZURRO SKY/SKY BLUE**  
.....  
DONNA / WOMAN

S	606093M00A
M	606093M01A
L	606093M02A
XL	606093M03A

**GIACCA IN TESSUTO  
TEXTILE JACKET**

Pratiche, funzionali, protettive e adatte ad ogni stagione. Queste giacche in tessuto tecnico, dotate di protezioni rimovibili spalle e gomiti, hanno un design originale e grande attenzione nella cura dei dettagli. *Versatile, functional, protective and for all season use, these textile jackets, with remouvable shoulders and elbows protectors, show an original design and great attention to every detail.*

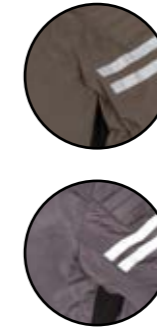
**GRIGIO/GREY**  
.....  
UOMO / MAN

S	606110M00G
M	606110M01G
L	606110M02G
XL	606110M03G
XXL	606110M04G

**VINTAGE GREEN**  
.....  
UOMO / MAN

S	606110M00V
M	606110M01V
L	606110M02V
XL	606110M03V
XXL	606110M04V

**GRIGIO/GREY**  
.....  
DONNA / WOMAN

S	606111M00G
M	606111M01G
L	606111M02G
XL	606111M03G
XXL	606111M04G

**VINTAGE GREEN**  
.....  
DONNA / WOMAN

S	606111M00V
M	606111M01V
L	606111M02V
XL	606111M03V
XXL	606111M04V

**GIACCA RACER  
RACER JACKET**  
UOMO / MAN

**GIACCA TOURING  
TOURING JACKET**  
UOMO / MAN

**PANTALONI TOURING  
TOURING PANTS**  
UOMO / MAN

**VINTAGE**  
.....

XS	B063963
S	B063964
M	B063965
L	B063966
XL	B063967
XXL	B063968

**NERO/BLACK**  
.....

S	605797M022
M	605797M032
L	605797M042
XL	605797M052
XXL	605797M062
XXXL	605797M072

**NERO/BLACK**  
.....

S	605798M022
M	605798M032
L	605798M042
XL	605798M052
XXL	605798M062
XXXL	605798M072



**T-SHIRT MY BIKE MY PRIDE**  
 UOMO / MAN

T-shirt uomo in 100% cotone.  
 Stampa fronte in rilievo gommata.  
 Stampa retro logo Moto Guzzi.

*Man 100% cotton t-shirt.  
 Relief printing on the front.  
 Moto Guzzi logo print on the back.*

**VERDE/GREEN**  
 .....

S	606033M02V
M	606033M03V
L	606033M04V
XL	606033M05V
XXL	606033M06V

**NERO/BLACK**  
 .....

S	606033M02N
M	606033M03N
L	606033M04N
XL	606033M05N
XXL	606033M06N

**BLU/BLUE**  
 .....

S	606033M02B
M	606033M03B
L	606033M04B
XL	606033M05B
XXL	606033M06B

**T-SHIRT MOTO GUZZI**  
 UOMO / MAN

T-shirt uomo in 100% cotone.  
 Stampa fronte logo Moto Guzzi con  
 colore ad acqua.

*Man 100% cotton t-shirt.  
 Moto Guzzi logo print on front with  
 color water.*

**NERO/BLACK**  
 .....

S	606037M02N
M	606037M03N
L	606037M04N
XL	606037M05N
XXL	606037M06N

**VERDE/GREEN**  
 .....

S	606037M02V
M	606037M03V
L	606037M04V
XL	606037M05V
XXL	606037M06V

**T-SHIRT LOGO**  
 UOMO / MAN

T-shirt uomo in 100% cotone.  
 Stampa con colore ad acqua. Fronte logo  
 Moto Guzzi. Disegno moto sul retro.

*Man 100% cotton t-shirt. Color printing  
 with water. Moto Guzzi logo print on  
 front. Bike desing on the back.*

**GRIGIO/GREY**  
 .....

S	606034M02G
M	606034M03G
L	606034M04G
XL	606034M05G
XXL	606034M06G

**T-SHIRT 19 21**  
 UOMO / MAN

T-shirt uomo in 100% cotone.  
 Stampa con colore ad acqua sul fronte.  
 Logo Moto Guzzi sul retro.

*Man 100% cotton t-shirt.  
 Color printing with water on front.  
 Moto Guzzi logo print on the back.*

**GRIGIO/GREY**  
 .....

S	606036M02G
M	606036M03G
L	606036M04G
XL	606036M05G
XXL	606036M06G

**T-SHIRT SERAFINO**  
 UOMO / MAN

T-shirt uomo in 100% cotone.  
 Stampa con colore ad acqua.  
 Fronte logo Moto Guzzi.  
 Disegno moto sul retro.

*Man 100% cotton t-shirt.  
 Color printing with water.  
 Moto Guzzi logo print on front.  
 Bike desing on the back.*

**GRIGIO/GREY**  
 .....

S	606038M02G
M	606038M03G
L	606038M04G
XL	606038M05G
XXL	606038M06G

**NERO/BLACK**  
 .....

S	606038M02N
M	606038M03N
L	606038M04N
XL	606038M05N
XXL	606038M06N





**MOTO GUZZI®**

**T-SHIRT MY BIKE MY PRIDE**

DONNA / WOMAN

T-shirt donna in 100% cotone.  
Stampa fronte in rilievo gommata.  
Stampa retro logo Moto Guzzi.

Woman 100% cotton t-shirt.  
Relief printing on the front.  
Moto Guzzi logo print on the back.



**NERO/BLACK**

.....

<b>S</b>	606041M02N
<b>M</b>	606041M03N
<b>L</b>	606041M04N
<b>XL</b>	606041M05N

**VERDE/GREEN**

.....

<b>S</b>	606041M02V
<b>M</b>	606041M03V
<b>L</b>	606041M04V
<b>XL</b>	606041M05V

**BLU/BLUE**

.....

<b>S</b>	606041M02B
<b>M</b>	606041M03B
<b>L</b>	606041M04B
<b>XL</b>	606041M05B

**FELPA CUSTOM PUZZLE  
SWEATSHIRT CUSTOM PUZZLE**

UOMO / MAN

Felpa uomo maniche raglan in 100% cotone.  
Stampa fronte disegno con colore ad acqua.  
Logo Moto Guzzi sul retro.

Man 100% cotton sweatshirt.  
Color printing with water on front.  
Moto Guzzi logo print on the back.



**NERO/BLACK**

.....

<b>S</b>	606039M02N
<b>M</b>	606039M03N
<b>L</b>	606039M04N
<b>XL</b>	606039M05N
<b>XXL</b>	606039M06N

**FELPA MY BIKE MY PRIDE  
SWEATSHIRT MY BIKE MY PRIDE**

UOMO / MAN

Felpa uomo maniche raglan in 100% cotone.  
Stampa fronte disegno con colore ad acqua.  
Logo Moto Guzzi sul retro.

Man 100% cotton sweatshirt.  
Color printing with water on front.  
Moto Guzzi logo print on the back.



**VERDE/GREEN**

.....

<b>S</b>	606039M02V
<b>M</b>	606039M03V
<b>L</b>	606039M04V
<b>XL</b>	606039M05V
<b>XXL</b>	606039M06V

**CANOTTA MOTO GUZZI  
TANK TOP MOTO GUZZI**

DONNA / WOMAN

Canotta donna in 100% cotone.  
Logo Moto Guzzi sul fronte  
stampato ad acqua.

Woman 100% cotton tank top.  
Moto Guzzi logo print on front  
with color water.



**NERO/BLACK**

.....

<b>S</b>	606042M02N
<b>M</b>	606042M03N
<b>L</b>	606042M04N
<b>XL</b>	606042M05N

**VERDE/GREEN**

.....

<b>S</b>	606042M02V
<b>M</b>	606042M03V
<b>L</b>	606042M04V
<b>XL</b>	606042M05V

**FELPA CUSTOM PUZZLE  
SWEATSHIRT CUSTOM PUZZLE**

UOMO / MAN

Felpa uomo in 100% cotone.  
Logo Moto Guzzi sul fronte.  
Stampa moto sul retro.

Man 100% cotton sweatshirt.  
Moto Guzzi logo on front.  
Bike desing print on the back.



**GRIGIO/GREY**

.....

<b>S</b>	606040M02G
<b>M</b>	606040M03G
<b>L</b>	606040M04G
<b>XL</b>	606040M05G
<b>XXL</b>	606040M06G

**FELPA MY BIKE MY PRIDE  
SWEATSHIRT MY BIKE MY PRIDE**

UOMO / MAN

Felpa uomo in 100% cotone.  
Logo Moto Guzzi sul fronte.  
Stampa moto sul retro.

Man 100% cotton sweatshirt.  
Moto Guzzi logo on front.  
Bike desing print on the back.



**ROSSO/RED**

.....

<b>S</b>	606040M02R
<b>M</b>	606040M03R
<b>L</b>	606040M04R
<b>XL</b>	606040M05R
<b>XXL</b>	606040M06R



**FELPA CUSTOM PUZZLE  
SWEATSHIRT CUSTOM PUZZLE  
DONNA/ WOMAN**

Felpa donna in 100% cotone.  
Stampa con colore ad acqua.  
Fronte logo Moto Guzzi.  
Disegno moto sul retro.

Woman 100% cotton sweatshirt.  
Moto Guzzi logo on front.  
Bike desing print on the back.



**GRIGIO/GREY**

S	606043M02G
M	606043M03G
L	606043M04G
XL	606043M05G

**FELPA MY BIKE MY PRIDE  
SWEATSHIRT MY BIKE MY PRIDE  
DONNA/ WOMAN**

Felpa donna in 100% cotone.  
Stampa con colore ad acqua.  
Fronte logo Moto Guzzi.  
Disegno moto sul retro.

Woman 100% cotton sweatshirt.  
Moto Guzzi logo on front.  
Bike desing print on the back.



**ROSSO/RED**

S	606043M02R
M	606043M03R
L	606043M04R
XL	606043M05R

**T-SHIRT KID MOTO GUZZI  
BIMBO/ KID**

T- shirt kids in 100% cotone.  
Stampa logo Moto Guzzi sul fronte.  
Kids 100% cotton t-shirt.  
Moto Guzzi logo print on the front.



**NERO/BLACK**

4/6 ANNI AGE 4/6	606238M01N
6/8 ANNI AGE 6/8	606238M02N
8/10 ANNI AGE 8/10	606238M03N
10/12 ANNI AGE 10/12	606238M04N

**FELPA MY BIKE MY PRIDE  
SWEATSHIRT MY BIKE MY PRIDE  
BIMBO/ KID**

Felpa kids con cappuccio 100% cotone.  
Stampa moto gommata sul fronte  
Kids 100% cotton hooded sweatshirt.  
Relief bike printing on the front.



**GRIGIO/GREY**

6/8 ANNI AGE 6/8	606237M01G
8/10 ANNI AGE 8/10	606237M02G
10/12 ANNI AGE 10/12	606237M03G

**MASCHERA IN PELLE  
GOGGLES**

Maschera in pelle Moto Guzzi. Rifinite nei minimi particolari. Disponibili in due colorazioni, nere e marroni, entrambe con lenti azzurre per attenuare i raggi UV.

Moto Guzzi Vintage Rider Refined in every small detail. Available in two colors, black and brown, both with blue lenses to attenuate UV rays.



**NERO/BLACK**  
COD. 606009M001



**MARRONE/BROWN**  
COD. 606009M002

**OCCHIALI MOTO GUZZI  
MOTO GUZZI SUNGLASSES**

Gli occhiali Moto Guzzi sono una riedizione del classico modello vintage a goccia in chiave moderna, il colore nero opaco e le lenti specchio sfumate lo rendono elegante e sportivo allo stesso tempo.

Caratteristiche:  
montatura in materiale Tr90; lenti infrangibili Cr39; montatura colore nero opaco; lenti grigio/verde specchio sfumate.



**NERO/BLACK**  
COD. 606235M

Moto Guzzi sunglasses are a remake of the classic drop shape vintage model into a modern version. Matt black color and gradient mirror lenses make it elegant and sporty at the same time.  
Features:  
frame material Tr90; shatterproof lenses CR39; rame matt black, lenses in grey/green gradient mirror.

**CINTURE MOTO GUZZI  
MOTO GUZZI BELTS**



**MARRONE/BROWN**  
COD. 605862M0B0

Cintura Moto Guzzi con fibbia ovale smaltata azzurra.  
Moto Guzzi belt with light blue oval anameled buckle.



**MARRONE/BROWN**  
COD. 605922MBN

Cintura Moto Guzzi con fibbia ovale smaltata nera.  
Moto Guzzi belt with black oval anameled buckle.



**NERO/BLACK**  
COD. 605862M0FI

Cintura Moto Guzzi classica.  
Moto Guzzi classic belt with embossed logo.

**BORSA DA VIAGGIO  
TRAVEL BAG**

Tessuto tecnico con ampi manici e inserti in pelle, completa di tracolla regolabile. Logo Moto Guzzi su patch in pelle.

Technical fabric bag with long handles and leather inserts, complete with adjustable shoulder strap. Moto Guzzi logo patch on leather.



**NERO/BLACK**  
COD. B063423



**BANDANA**

Bandana unisex 100% cotone  
Bandana unisex 100% cotton.

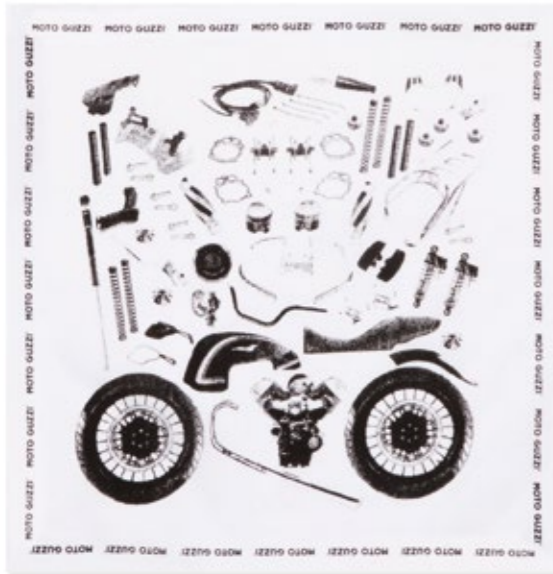

**BIANCO/WHITE**  
.....  
COD. 606046M00W



**NERO/BLACK**  
.....  
COD. 606046M00B

**SCALDACOLLO  
TOURTLENECK**

Scaldacollo unisex 100% cotone. Stampa con colore ad acqua. In versione semplice o micropile.  
Turtleneck unisex 100% cotton. Print with color water. Micropile and basic version.



**SCALDACOLLO MICROPILE GRIGIO  
TOURTLENECK MICROPILE GREY**  
.....  
COD. 606044M00G



**SCALDACOLLO MICROPILE NERO  
TOURTLENECK MICROPILE BLACK**  
.....  
COD. 606044M00N



**SCALDACOLLO GRIGIO  
NECK WARMER GREY**  
.....  
COD. 606045M00G



**SCALDACOLLO NERO  
NECK WARMER BLACK**  
.....  
COD. 606045M00N

**MG ZIP  
GUANTI / GLOVES**

Il modello "Stripes" ha due fasce riflettenti sul dorso e regolazione della chiusura sul polso in velcro. Il modello "Zip" ha invece cuciture a contrasto sul dorso e chiusura polso con Zip. Sono guanti Estivi, comodi, provvisti di rinforzo sul palmo ed inserti in silicone su indice e medio per un migliore controllo delle leve freno e frizione. Sono marchiati Moto Guzzi, all'interno del polso, con stampa oro.

4 Taglie Unisex S - XL  
*made in bovine full grain leather, very soft but tested for abrasion resistance. Both model are in black color: "Stripes" gloves show two reflective stripes on the top and Velcro wrist closure. "Zip" gloves have contrast stitching on top of the knuckles, with soft padding, and a Zipper wrist closure. Branded by a golden print Moto Guzzi logo, are made in 4 unisex sizes from S to XL*



**NERO/BLACK**  
.....  
**S** | 606082M02Z  
**M** | 606082M03Z  
**L** | 606082M04Z  
**XL** | 606082M05Z



**NERO/BLACK**  
.....  
**S** | 606081M02S  
**M** | 606081M03S  
**L** | 606081M04S  
**XL** | 606081M05S

**WINTER TOURING  
GUANTI / GLOVES**

guanti misto pelle tessuto, dotati di membrana impermeabile e membrana termica, con protezioni rigide sulle nocche e cuscinetto in schiuma poliuretanicca sul palmo. Logo Moto Guzzi ricamato e applicato su patch in gomma.

*Texile 6 leather gloves with waterproof membrane and thermal lining. PU knuckle protectors and foam cushion on palm. Embroidered Moto Guzzi Logo applied on a rubber patch.*



**NERO/BLACK**  
.....  
**S** | 887104  
**M** | 887105  
**L** | 887106  
**XL** | 887107  
**XXL** | 887108

**STREET SUMMER  
GUANTI / GLOVES**

Guanto misto pelle-tessuto traforato con protezioni nocche in schiuma poliuretanicca, parti elasticizzate su polso e falangi e cuscinetto in schiuma poliuretanicca sul palmo. Logo Moto Guzzi ricamato e applicato su patch in gomma.

*Leather and air mesh textile gloves with foam knuckle protectors and foam cushion on palm. Embroidered Moto Guzzi Logo applied on a rubber patch.*



**NERO/BLACK**  
.....  
**S** | 887109  
**M** | 887110  
**L** | 887111  
**XL** | 887112  
**XXL** | 887113



### T-SHIRT THE CLAN

UOMO / MAN

T-shirt 100% cotone  
Stampa Fronte Moto Guzzi «the clan»  
Stampa retro Moto Guzzi

100% cotton T-shirt  
Moto Guzzi «the clan» print on the front  
Moto Guzzi print on the back



NERO/BLACK

S	606049M022
M	606049M032
L	606049M042
XL	606049M052
XXL	606049M062

NERO/BLACK

M	606011M032
L	606011M042
XL	606011M052
XXL	606011M062

### CAPPELLO BASEBALL BASEBALL CAP

100% cotone  
Logo Moto Guzzi ricamato

100% cotton  
Embroidered Moto Guzzi Logo



COD. 606010M

### T-SHIRT THE CLAN

DONNA/ WOMAN

T-shirt 100% cotone  
Stampa Fronte Moto Guzzi «the clan»  
Stampa retro Moto Guzzi

100% cotton T-shirt  
Moto Guzzi «the clan» print on the front  
Moto Guzzi print on the back



NERO/BLACK

XS	606050M012
S	606050M022
M	606050M032
L	606050M042
XL	606050M052

NERO/BLACK

S	606012M022
M	606012M032
L	606012M042
XL	606012M052

### PATCH THE CLAN



COD. 606013M002



COD. 606013M001







Le descrizioni dei prodotti e degli accessori presenti in questo catalogo (dimensioni, misure, specifiche) sono basate su informazioni disponibili al momento della pubblicazione.

Moto Guzzi si riserva il diritto di effettuare in qualsiasi momento modifiche alle descrizioni e alle specifiche o di cambiare o mettere in discontinuità qualsiasi oggetto presente in questo catalogo senza alcun obbligo di comunicazione e senza incorrere in alcuna obbligazione.

*All products and accessories description (measurement, dimensions, specifications) are based on available information at the time of publication. Moto Guzzi may make changes at any time to specifications and description and may change or discontinue any of the items included in this catalogue, without notice and without incurring any obligations.*